

DELTA

3641SEP160P63

EAN 4031582355161

Swivel castor with directional lock, housing made of heavy pressed steel, bright zinc plated, blue passivated, precision ball bearing swivel head, sealed, wheel axle with nut, plate fitting. Wheel centre made of pressed steel, welded and painted, tread made of vulcanized black elastic-tyre, precision ball bearing



BETTER MOBILITY. BETTER LIFE.



Picture may differ from original product

Technical Data

Wheel diameter	160 mm
Wheel width	50 mm
Castor width	94 mm
Size of Plate	137 x 105 mm
Plate hole centres	105 x 80/75 mm
Plate hole	11 mm
Dome-Ø	94 mm
Offset	55 mm
Swivel Interference	270 mm
Overall height	210 mm
Temperature	- 20 / + 85 °C
Standard	EN_12532
Weight	3.875 kg
Swivel Radius	135 mm
Hardness of tread	Shore A 67
Load capacity	540 kg
Load capacity (static)	1080 kg

Dimensions

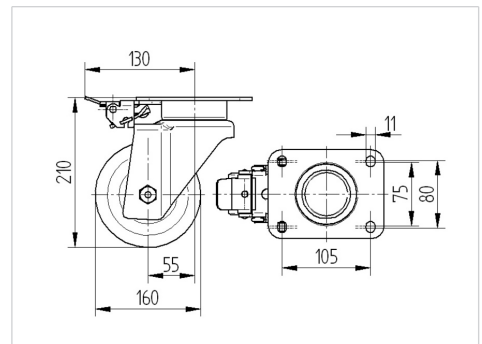

Structure & Mounting

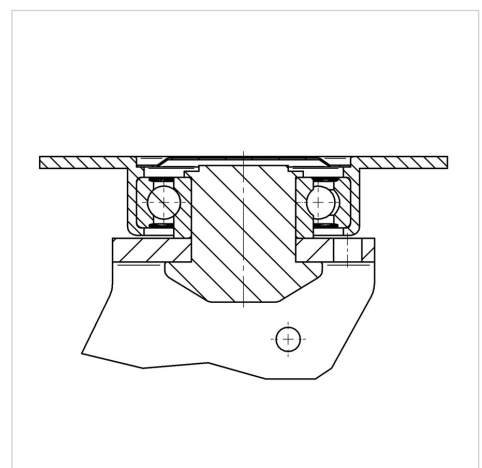

Advantages at a glance

Roll performance	● ● ● ○ ○
Movement noise	● ● ● ● ●
Attrition	● ● ● ○ ○
Corrosion resistance	● ● ● ○ ○

DELTA

3641SEP160P63

EAN 4031582355161



BETTER MOBILITY. BETTER LIFE.

Structure & Mounting

