

# DELTA

3642U00160P63

EAN 4031582337839

Swivel castor with total lock, head end of castor, housing made of heavy pressed steel, bright zinc plated, blue passivated, precision ball bearing swivel head, sealed, wheel axle with nut, plate fitting. Wheel centre made of Polyamide, plain bearing



BETTER MOBILITY. BETTER LIFE.



Picture may differ from original product

## Technical Data

Wheel diameter	160 mm
Wheel width	46 mm
Castor width	94 mm
Size of Plate	137 x 105 mm
Plate hole centres	105 x 80/75 mm
Plate hole	11 mm
Dome-Ø	94 mm
Offset	55 mm
Swivel Interference	270 mm
Overall height	210 mm
Temperature	- 40 / + 85 °C
Standard	EN_12532
Weight	2.688 kg
Swivel Radius	135 mm
Hardness of tread	Shore D 75
Load capacity	500 kg
Load capacity (static)	1000 kg

## Structure & Mounting

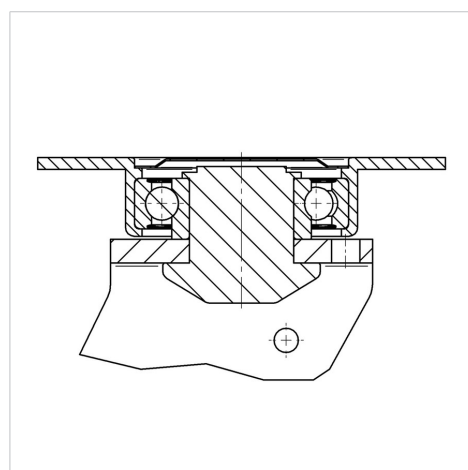

## Advantages at a glance

Roll performance	● ● ● ○ ○
Movement noise	● ● ● ○ ○
Attrition	● ● ● ● ●
Corrosion resistance	● ● ● ○ ○

# DELTA

3642UOO160P63

EAN 4031582337839



BETTER MOBILITY. BETTER LIFE.

## Structure & Mounting

