

# STORA

## 3875ZJJ160P63 LEFT

EAN 4031582328561

Walkway Castor with automatic side brake for moving walkways, housing made of pressed steel, bright zinc plated, blue passivated, double ball bearing swivel head, flanged wheel with one ball race, left and right hand design, wheel axle with nut, Wheel centre made of plastic, Tread: TENTEprene (thermoplastic rubber), with threadguards, roller bearing. Designed for the following palletsize: track width: approx: 2,75 mm, groove width: approx. 5,7 mm, groove depth: > 10 mm.

Hint:

Load capacity 160 kg per castor on level and securely attached floors, 40 kg per castor on walkways. Use on uneven floors, outdoors (ground beams, gaps, joints, manhole covers, etc.) can affect the life expectancy of castors.



BETTER MOBILITY. BETTER LIFE.



Picture may differ from original product

### Technical Data

Wheel diameter	160 mm
Wheel width	40 mm
Castor width	96 mm
Size of Plate	137 x 105 mm
Plate hole centres	105 x 80/75 mm
Plate hole	11 mm
Dome-Ø	96 mm
Offset	55 mm
Swivel Interference	270 mm
Overall height	191 mm
Temperature	- 20 / + 60 °C
Standard	EN_12532
Weight	2.063 kg
Swivel Radius	135 mm
Hardness of tread	Shore A 87
Load capacity	160 kg
Load capacity (static)	320 kg

### Structure & Mounting

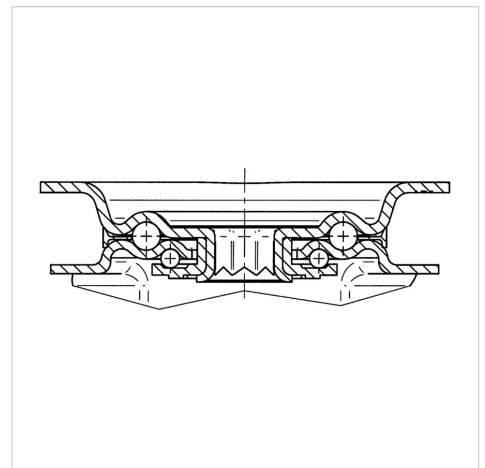

### Advantages at a glance

Roll performance	● ● ● ○ ○
Movement noise	● ● ● ○ ○
Attrition	● ● ● ○ ○
Corrosion resistance	● ● ● ○ ○

# STORA

3875ZJJ160P63 LEFT

EAN 4031582328561



BETTER MOBILITY. BETTER LIFE.

## Structure & Mounting

---

