

LINEA

594CUAP125R05-28 RAL9002

EAN 4031582378429

Combined swivel castor with wheel brake and directional lock function, housing made of Polyamide, precision ball bearing in swivel head, solid plug fitting. Wheel centre made of Polyamide, Tread: Polyurethane, precision ball bearing



BETTER MOBILITY. BETTER LIFE.



Picture may differ from original product

Technical Data

Wheel diameter	125 mm
Wheel width	20 mm
Castor width	82 mm
Bolt-Ø	28 mm
Bolt length	40 mm
Dome-Ø	52 mm
Offset	40 mm
Swivel Interference	258 mm
Overall height	145 mm
Temperature	-20/+60 °C
Standard	EN_12530
Weight	1.18 kg
Swivel Radius	129 mm
Hardness of tread	Shore A 92
Load capacity	130 kg
Load capacity (static)	260 kg

Advantages at a glance

Roll performance	● ● ● ● ●
Movement noise	● ● ● ○ ○
Attrition	● ● ● ● ○
Corrosion resistance	● ● ● ● ○

Dimensions

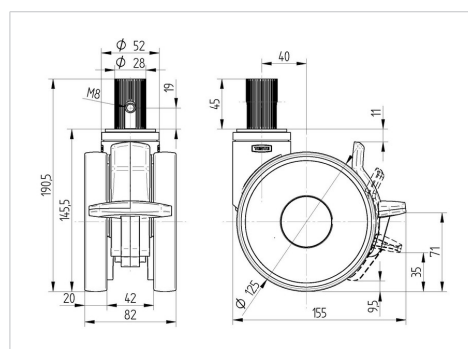

Structure & Mounting

