

LINEA

5944UAP150R36-32S27 safety OH155

EAN 4031582412765

Swivel castor with central, total lock and central directional lock, housing made of Polyamide, precision ball bearing in swivel head. Swivel castor with automatic locking system, stem with cam hole for profile bars, short version. Wheel centre made of Polyamide, Tread: Polyurethane, precision ball bearing

:
The LINEA safety with dead man brake is designed/suitable for equipment with a low centre of gravity (e.g. hospital beds). It causes the equipment to brake automatically and immediately as soon as the control lever or handle is released. If used for equipment with a higher centre of gravity, a joint technical assessment is necessary in accordance with product liability law.



BETTER MOBILITY. BETTER LIFE.



Picture may differ from original product

Technical Data

Wheel diameter	150 mm
Wheel width	15 mm
Castor width	71 mm
Bolt-Ø	32 mm
Bolt length	50 mm
Offset	47.5 mm
Swivel Interference	254 mm
Overall height	155 mm
Temperature	- 10 / + 40 °C
Standard	similar_EN12531
Weight	1.115 kg
Swivel Radius	122.5 mm
Load capacity	150 kg
Load capacity (static)	450 kg

Advantages at a glance

Roll performance	● ● ● ● ●
Movement noise	● ● ● ○ ○
Attrition	● ● ● ● ○
Corrosion resistance	● ● ● ● ○

Dimensions

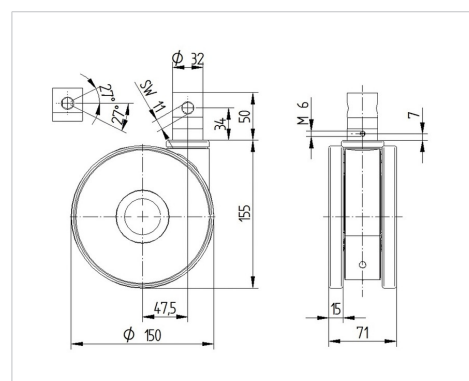

Structure & Mounting

