

LEVINA LIGHT

5220PJP100S70-1/2-13x1

EAN 4031582492811

Swivel castor, Housing made of glass-filled Polyamide, threaded stem with hexagon neck. Wheel centre made of Polypropylene, Tread: TENTEprene (thermoplastic rubber), grey non-marking, precision ball bearing



BETTER MOBILITY. BETTER LIFE.



Picture may differ from original product

Technical Data

Wheel diameter	100 mm
Wheel width	32 mm
Threaded stem	1/2-13X1 mm
Offset	36 mm
Swivel Interference	172 mm
Overall height	146.3 mm
Temperature	- 10 / + 40 °C
Standard	EN_12530
Swivel Radius	86 mm
Hardness of tread	Shore A 87
Fitting-Hole-Ø	11 mm
Load capacity	82 kg
Suitable wheel sizes	100 mm

Dimensions

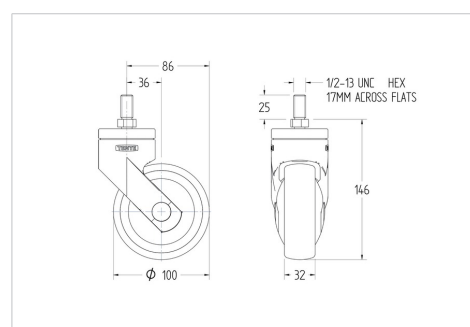

Advantages at a glance

Roll performance	● ● ● ○ ○
Movement noise	● ● ● ● ○
Attrition	● ● ● ○ ○
Corrosion resistance	● ● ● ● ○