

# INTEGRAL TWIN

2944UAP125R26-28S45 RAL9002 4xM8

EAN 4031582302547

Swivel castor with central, total lock and central directional lock, frame made of pressed steel, precision ball bearing in swivel head, housing with synthetic cover, stem with cam hole for profile bars. Wheel centre made of Polyamide, Tread: Polyurethane, precision ball bearing  
Hint: TÜV Süd certified product.



BETTER MOBILITY. BETTER LIFE.



Picture may differ from original product

## Technical Data

Wheel diameter	125 mm
Wheel width	12 mm
Castor width	63 mm
Bolt-Ø	28 mm
Bolt length	96 mm
Dome-Ø	61.5 mm
Offset	37.5 mm
Swivel Interference	206 mm
Overall height	150 mm
Temperature	- 25 / - 25 °C
Standard	EN_12531
Weight	1.161 kg
Swivel Radius	103 mm
Hardness of tread	Shore D 42
Load capacity	125 kg
Load capacity (static)	375 kg

## Dimensions

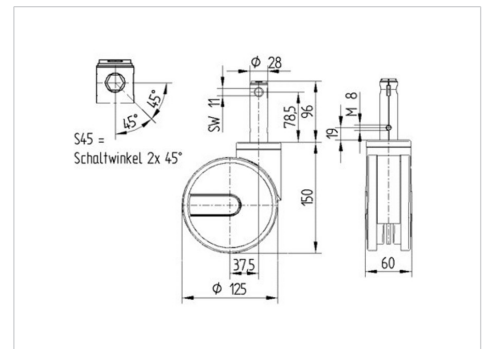

## Advantages at a glance

Roll performance	● ● ● ● ●
Movement noise	● ● ● ○ ○
Attrition	● ● ● ● ○
Corrosion resistance	● ● ● ○ ○

# INTEGRAL TWIN

2944UAP125R26-28S45 RAL9002 4xM8

EAN 4031582302547



BETTER MOBILITY. BETTER LIFE.

## Structure & Mounting

---

