

LINEA

5927UAP075S70-M10x15 LN EN12530
RAL7001

EAN 4031582414783

Swivel castor with total lock, tail end of castor, housing made of Polyamide, threaded stem with hexagon neck. Wheel centre made of Polyamide, Tread: Polyurethane, precision ball bearing



BETTER MOBILITY. BETTER LIFE.



Picture may differ from original product

Technical Data

Wheel diameter	75 mm
Wheel width	15 mm
Castor width	55 mm
Threaded stem	M10x15 mm
Offset	23 mm
Swivel Interference	164 mm
Overall height	81 mm
Temperature	-20/+60 °C
Standard	EN_12530
Weight	0.222 kg
Swivel Radius	82 mm
Load capacity	80 kg
Load capacity (static)	160 kg

Structure & Mounting

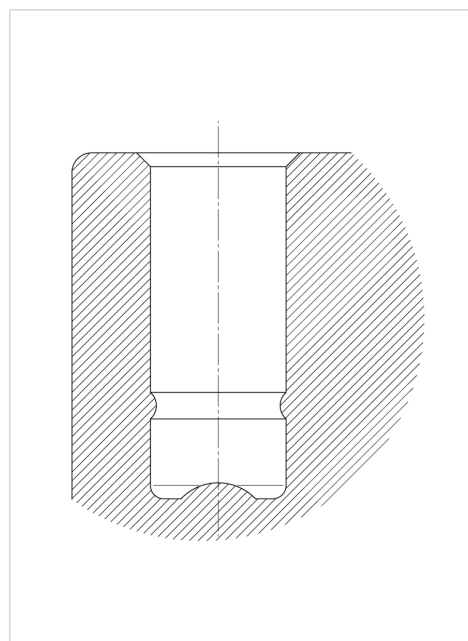

Advantages at a glance

Roll performance	● ● ● ● ○
Movement noise	● ● ● ○ ○
Attrition	● ● ● ○ ○
Corrosion resistance	● ● ● ● ○