

# GALEA

5087PJC125P60-90x70

EAN 4031582367997

Swivel castor with total lock, tail end of castor, housing made of Polyamide, double ball bearing swivel head, plate fitting. Wheel centre made of Polypropylene, Tread: TENTEprene (thermoplastic rubber), grey non-marking, with threadguards, precision ball bearing, stainless Steel version. All Metal parts made of Stainless Steel.



BETTER MOBILITY. BETTER LIFE.



Picture may differ from original product

## Technical Data

|                        |                  |
|------------------------|------------------|
| Wheel diameter         | 125 mm           |
| Wheel width            | 30 mm            |
| Size of Plate          | 90 x 70 mm       |
| Plate hole centres     | 70/60 x 55/50 mm |
| Plate hole             | 8 mm             |
| Offset                 | 40 mm            |
| Swivel Interference    | 205 mm           |
| Overall height         | 163 mm           |
| Temperature            | -20 / +60 °C     |
| Standard               | EN_12530         |
| Weight                 | 0.574 kg         |
| Hardness of tread      | Shore A 87       |
| Load capacity          | 100 kg           |
| Load capacity (static) | 200 kg           |

## Structure & Mounting

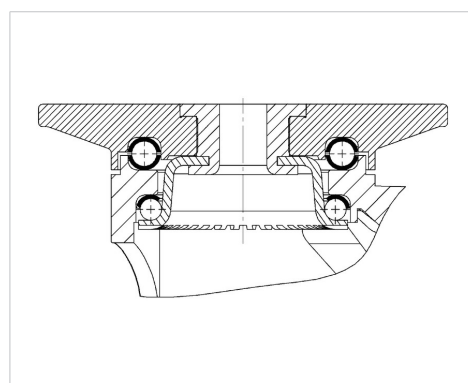

## Advantages at a glance

|                      |           |
|----------------------|-----------|
| Roll performance     | ● ● ● ○ ○ |
| Movement noise       | ● ● ● ○ ○ |
| Attrition            | ● ● ● ○ ○ |
| Corrosion resistance | ● ● ● ● ● |