



BETTER MOBILITY. BETTER LIFE.

## 5444PJP100R36-32S30 4xM6

EAN 4031582336771

Swivel castor with central, total lock and central directional lock, housing made of Polyamide, precision ball bearing in swivel head, with integrated threadguards, wheel axle with nut, stem with cam hole for profile bars, short version. Wheel centre made of Polypropylene, Tread: TENTEprene (thermoplastic rubber), grey non-marking, precision ball bearing



Picture may differ from original product

### Technical Data

Wheel diameter	100 mm
Wheel width	32 mm
Castor width	67 mm
Bolt-Ø	32 mm
Bolt length	51 mm
Dome-Ø	62 mm
Offset	38 mm
Swivel Interference	176 mm
Overall height	139 mm
Temperature	- 10 / + 40 °C
Standard	EN_12530
Weight	0.643 kg
Swivel Radius	88 mm
Hardness of tread	Shore A 87
Load capacity	100 kg
Load capacity (static)	200 kg

### Structure & Mounting

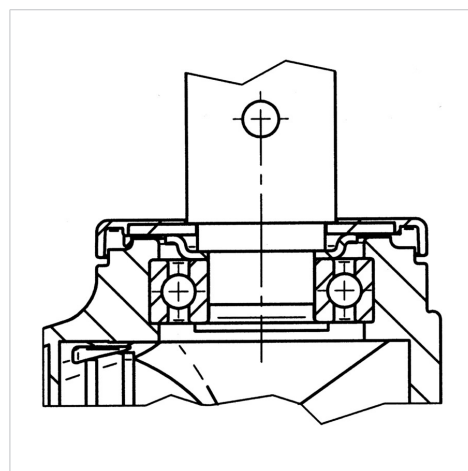

### Advantages at a glance

Roll performance	● ● ● ○ ○
Movement noise	● ● ● ○ ○
Attrition	● ● ● ○ ○
Corrosion resistance	● ● ● ● ○

5444PJP100R36-32S30 4xM6

EAN 4031582336771



BETTER MOBILITY. BETTER LIFE.

**Structure & Mounting**

---



reddot design award  
winner