

# LINEA

## 5940UAP050L51-8 load 7001

EAN 4031582421569

Swivel castor, housing made of Polyamide, precision ball bearing in swivel head, with blind hole fitting. Wheel centre made of Polyamide, Tread: Polyurethane, precision ball bearing



BETTER MOBILITY. BETTER LIFE.



Picture may differ from original product

### Technical Data

Wheel diameter	50 mm
Wheel width	13 mm
Castor width	47.5 mm
Centre hole	8 mm
Dome-Ø	23 mm
Swivel Interference	81 mm
Overall height	50.5 mm
Temperature	- 10 / + 40 °C
Standard	EN_12530
Weight	0.088 kg
Swivel Radius	40.5 mm
Hardness of tread	Shore A 92
Load capacity	100 kg
Load capacity (static)	200 kg

### Dimensions

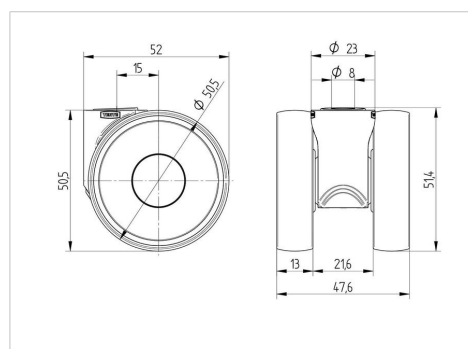

### Structure & Mounting

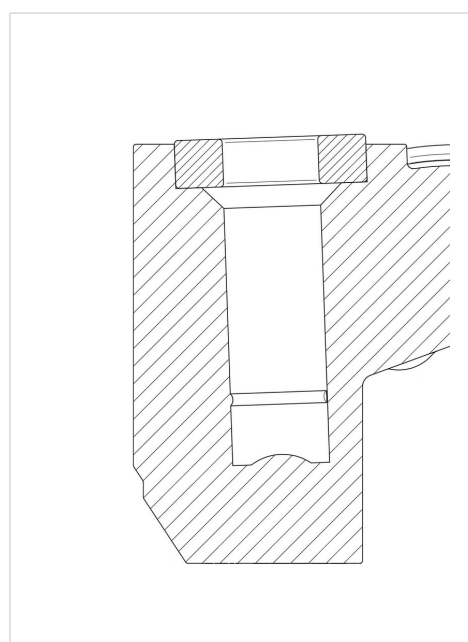

### Advantages at a glance

Roll performance	● ● ● ● ●
Movement noise	● ● ● ● ○
Attrition	● ● ● ● ●
Corrosion resistance	● ● ● ● ○