

AGILA TWIN

2976UAE075P54

EAN 4031582302882

Swivel castor with central total lock, housing made of pressed steel, bright zinc plated, blue passivated, double ball bearing swivel head, wheel axle with nut, plate fitting. Wheel centre made of Polyamide, Tread: Polyurethane, with threadguards, cone ball bearing stainless



BETTER MOBILITY. BETTER LIFE.



Picture may differ from original product

Technical Data

Wheel diameter	75 mm
Wheel width	25 mm
Size of Plate	70 x 55 mm
Plate hole centres	57/51 x 41 mm
Plate hole	5,5 mm
Offset	28 mm
Swivel Interference	131 mm
Overall height	103 mm
Temperature	- 20 / + 60 °C
Standard	EN_12530
Weight	0.67 kg
Swivel Radius	65.5 mm
Hardness of tread	Shore D 42
Load capacity	100 kg
Load capacity (static)	200 kg

Advantages at a glance

Roll performance	● ● ● ○ ○
Movement noise	● ● ● ○ ○
Attrition	● ● ● ● ○
Corrosion resistance	● ● ● ○ ○

Dimensions

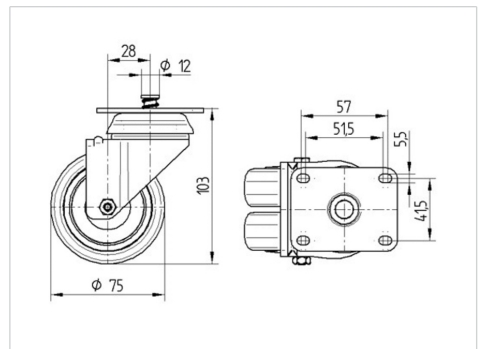

Structure & Mounting

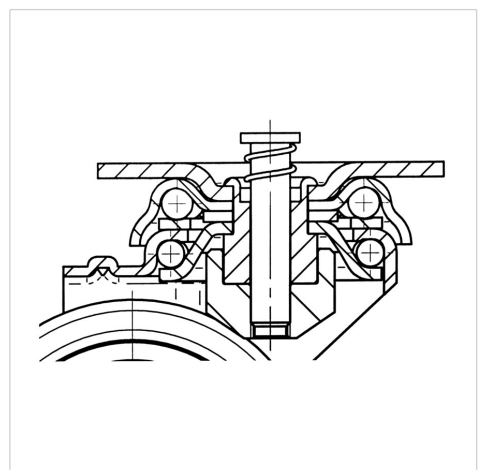

AGILA TWIN

2976UAE075P54

EAN 4031582302882



BETTER MOBILITY. BETTER LIFE.

Structure & Mounting

