

# LEVINA

5387UAC100P30-13

EAN 4031582369137

Swivel castor with total lock, tail end of castor, housing made from high grade synthetic materials with metal parts made of Stainless Steel, double ball bearing swivel head, bolt hole. Wheel centre made of polyamide, tread made of polyurethane, two INOX precision ball bearings, sealed, washable

Hint: These castors are also with grey locking lever available.



BETTER MOBILITY. BETTER LIFE.



Picture may differ from original product

## Technical Data

Wheel diameter	100 mm
Wheel width	32 mm
Centre hole	13 mm
Offset	36 mm
Swivel Interference	196 mm
Overall height	137 mm
Temperature	- 10 / + 40 °C
Standard	EN_12530
Swivel Radius	98 mm
Hardness of tread	Shore D 40
Load capacity	100 kg
Load capacity (static)	200 kg

## Advantages at a glance

Roll performance	● ● ● ○ ○
Movement noise	● ● ● ● ○
Attrition	● ● ● ● ○
Corrosion resistance	● ● ● ● ●

## Dimensions

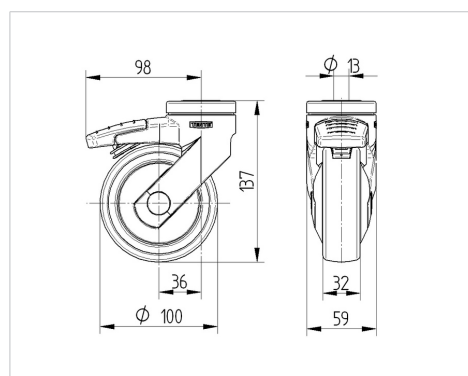

## Structure & Mounting

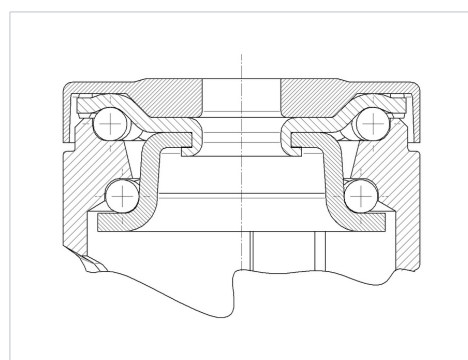

PRODUCT INFORMATION

# LEVINA

5387UAC100P30-13

EAN 4031582369137



BETTER MOBILITY. BETTER LIFE.

## Structure & Mounting

---

