

# AGILA

7477XSC150P50

EAN 4031582349627

Swivel castor with total lock, tail end of castor, housing made of Stainless Steel, double ball bearing swivel head, wheel axle with nut, zinc-die-casted chrome-plated brake pedal, plate fitting. Wheel centre made of Polyamide, electric conductive, tread made of Polyurethane, with threadguards, precision ball bearing, stainless



BETTER MOBILITY. BETTER LIFE.



Picture may differ from original product

## Technical Data

Wheel diameter	150 mm
Wheel width	32 mm
Castor width	60 mm
Size of Plate	77 x 67 mm
Plate hole centres	61,5/56 x 51,5/46,5 mm
Plate hole	8,5 mm
Dome-Ø	60 mm
Offset	36 mm
Swivel Interference	262 mm
Overall height	183 mm
Temperature	- 25 / + 60 °C
Standard	EN_12530
Weight	1.066 kg
Swivel Radius	131 mm
Hardness of tread	Shore A 91
Load capacity	100 kg
Load capacity (static)	200 kg

## Dimensions

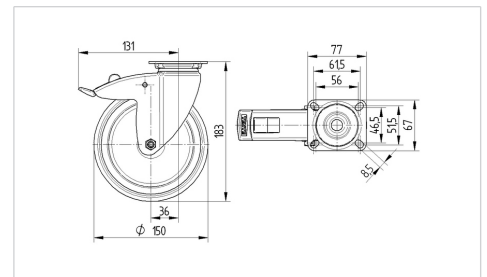

## Structure & Mounting

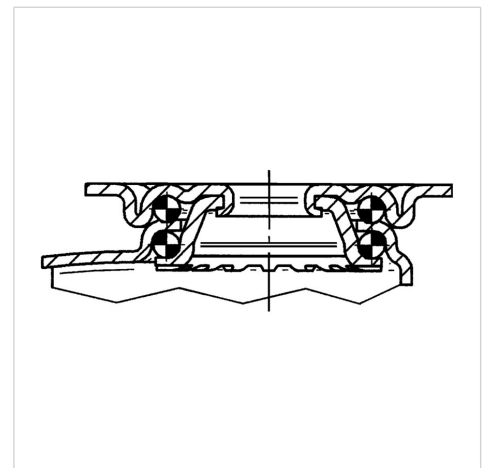

## Advantages at a glance

Roll performance	● ● ● ○ ○
Movement noise	● ● ● ○ ○
Attrition	● ● ● ○ ○
Corrosion resistance	● ● ● ● ●

# AGILA

7477XSC150P50

EAN 4031582349627



BETTER MOBILITY. BETTER LIFE.

## Structure & Mounting

