

# AGILA

7475PJH050P30-11

EAN 4031582351071

Swivel castor with wheel brake, housing made of Stainless Steel, double ball bearing swivel head, wheel axle with nut, brake pedal made of Polyamide, bolt hole. Wheel centre made of Polypropylene, Tread: TENTEprene (thermoplastic rubber), grey non-marking, with threadguards, plain bearing



BETTER MOBILITY. BETTER LIFE.



Picture may differ from original product

## Technical Data

Wheel diameter	50 mm
Wheel width	19 mm
Castor width	43 mm
Centre hole	11 mm
Dome-Ø	41 mm
Offset	24 mm
Swivel Interference	140 mm
Overall height	69 mm
Temperature	- 20 / + 60 °C
Standard	EN_12530
Weight	0.173 kg
Swivel Radius	70 mm
Hardness of tread	Shore A 87
Load capacity	50 kg
Load capacity (static)	100 kg

## Advantages at a glance

Roll performance	● ● ● ○ ○
Movement noise	● ● ● ○ ○
Attrition	● ● ● ○ ○
Corrosion resistance	● ● ● ● ●

## Dimensions

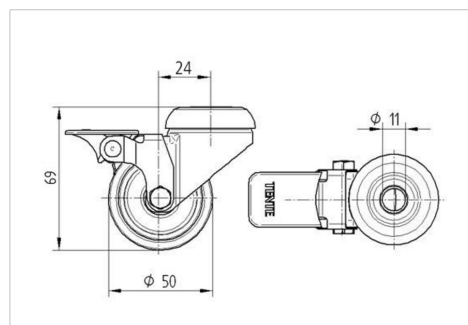

## Structure & Mounting

