

LEVINA

5387XSC125P30-13

EAN 4031582359473

Swivel castor with total lock, tail end of castor, housing made from high grade synthetic materials with metal parts made of Stainless Steel, double ball bearing swivel head, bolt hole. Wheel centre made of Polyamide, electric conductive, tread made of Polyurethane, with threadguards, precision ball bearing, stainless
 Hint: These castors are also with grey locking lever available.



BETTER MOBILITY. BETTER LIFE.



Picture may differ from original product

Technical Data

Wheel diameter	125 mm
Wheel width	32 mm
Centre hole	13 mm
Offset	38 mm
Swivel Interference	201 mm
Overall height	161 mm
Temperature	- 10 / + 40 °C
Standard	EN_12530
Swivel Radius	100.5 mm
Hardness of tread	Shore A 91
Load capacity	100 kg
Load capacity (static)	200 kg

Advantages at a glance

Roll performance	● ● ● ○ ○
Movement noise	● ● ● ● ○
Attrition	● ● ● ● ○
Corrosion resistance	● ● ● ● ●

Dimensions

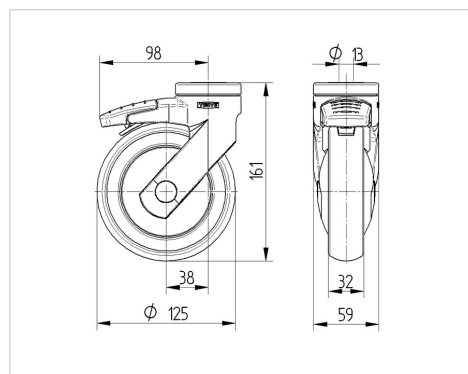

Structure & Mounting

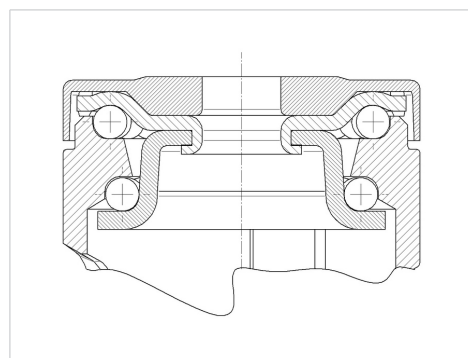

PRODUCT INFORMATION

LEVINA

5387XSC125P30-13

EAN 4031582359473



BETTER MOBILITY. BETTER LIFE.

Structure & Mounting

