

LEVINA

5380XSC125P50

EAN 4031582359558

Swivel castor, housing made from high grade synthetic materials with metal parts made of Stainless Steel, double ball bearing swivel head, plate fitting. Wheel centre made of Polyamide, electric conductive, tread made of Polyurethane, with threadguards, precision ball bearing, stainless



BETTER MOBILITY. BETTER LIFE.



Picture may differ from original product

Technical Data

| | |
|------------------------|------------------------|
| Wheel diameter | 125 mm |
| Wheel width | 32 mm |
| Size of Plate | 77 x 67 mm |
| Plate hole centres | 61,5/56 x 51,5/46,5 mm |
| Plate hole | 8,5 mm |
| Offset | 38 mm |
| Swivel Interference | 201 mm |
| Overall height | 161 mm |
| Temperature | - 10 / + 40 °C |
| Standard | EN_12530 |
| Swivel Radius | 100.5 mm |
| Hardness of tread | Shore A 91 |
| Load capacity | 100 kg |
| Load capacity (static) | 200 kg |

Advantages at a glance

| | |
|----------------------|-----------|
| Roll performance | ● ● ● ○ ○ |
| Movement noise | ● ● ● ● ○ |
| Attrition | ● ● ● ● ○ |
| Corrosion resistance | ● ● ● ● ● |

Dimensions

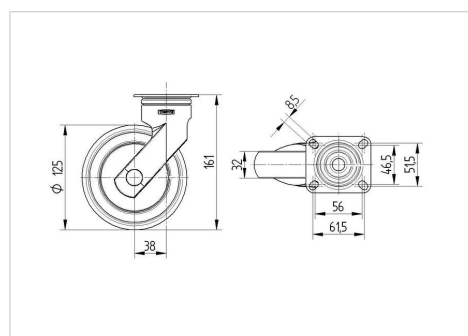

Structure & Mounting

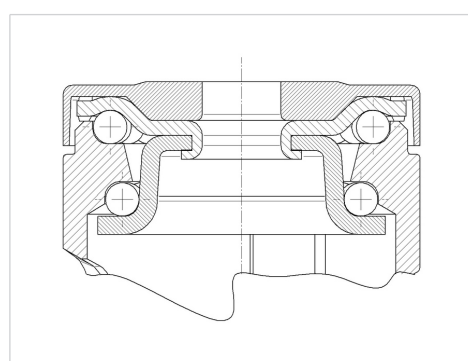

LEVINA

5380XSC125P50

EAN 4031582359558



BETTER MOBILITY. BETTER LIFE.

Structure & Mounting

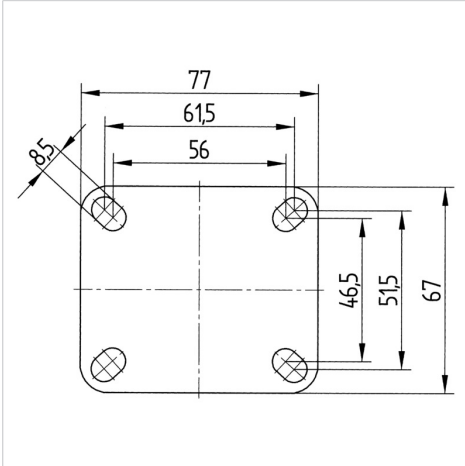

Design Award Winner

German Designer Club

