

# AGILA

2470UAK050P40

EAN 4031582301090

Swivel castor, housing made of pressed steel, bright zinc plated, blue passivated, double ball bearing swivel head, wheel axle with nut, plate fitting. Wheel centre made of Polyamide, Tread: Polyurethane, with threadguards, cone ball bearing



BETTER MOBILITY. BETTER LIFE.



Picture may differ from original product

## Technical Data

Wheel diameter	50 mm
Wheel width	20 mm
Castor width	43 mm
Size of Plate	60 x 60 mm
Plate hole centres	48/38 x 48/38 mm
Plate hole	6,3 mm
Dome-Ø	41 mm
Offset	24 mm
Swivel Interference	98 mm
Overall height	69 mm
Temperature	- 25 / - 25 °C
Standard	EN_12530
Weight	0.221 kg
Swivel Radius	49 mm
Hardness of tread	Shore D 42
Load capacity	50 kg
Load capacity (static)	100 kg

## Dimensions

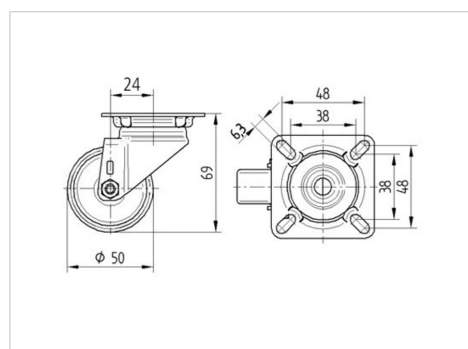

## Structure & Mounting

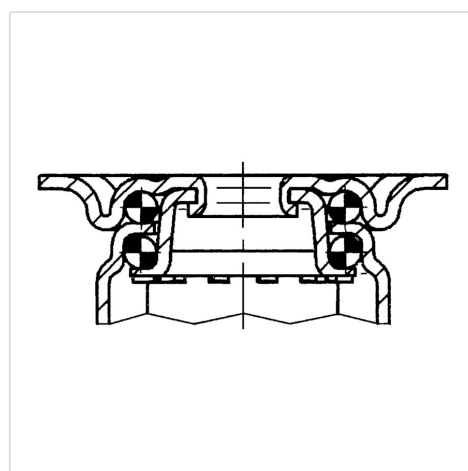

## Advantages at a glance

Roll performance	● ● ● ○ ○
Movement noise	● ● ● ○ ○
Attrition	● ● ● ● ○
Corrosion resistance	● ● ● ○ ○

# AGILA

2470UAK050P40

EAN 4031582301090



BETTER MOBILITY. BETTER LIFE.

## Structure & Mounting

