



BETTER MOBILITY. BETTER LIFE.

FOOT MASTER GAGD-125-ASF-HUD

EAN 4031582495294

Swivel twin wheel castor, housing made of steel welded, zinc plated, double thrust bearing in the swivel head, grease nipple, wheel axle with nut, plate fitting. Wheel centre made of cast iron, Tread: Polyurethane, casted, precision ball bearing.



Picture may differ from original product

Technical Data

Wheel diameter	125 mm
Wheel width	35 mm
Castor width	128 mm
Size of Plate	145 x 145,0 mm
Plate hole centres	120 x 120 mm
Plate hole	11 mm
Dome-Ø	130 mm
Offset	33 mm
Swivel Interference	200 mm
Overall height	175 mm
Temperature	-10 / +90 °C
Weight	10.68 kg
Swivel Radius	100 mm
Load capacity	440 kg

Dimensions

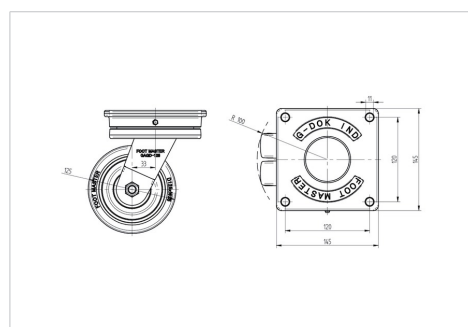

Advantages at a glance

Roll performance	● ● ● ● ●
Movement noise	● ● ● ● ○
Attrition	● ● ● ● ○
Corrosion resistance	● ● ● ● ○