

INTEGRAL

7046UAX150R26-28S45 4xM8

EAN 4031582311396

Swivel castor with central total lock, frame made of stainless steel, precision ball bearing in swivel head, housing cover made of synthetic plastics, washable, stem with cam hole for profile bars. Wheel centre made of Polyamide, Tread: Polyurethane, with threadguards, precision ball bearing, sealed



BETTER MOBILITY. BETTER LIFE.



Picture may differ from original product

Technical Data

Wheel diameter	150 mm
Wheel width	32 mm
Castor width	62 mm
Bolt-Ø	28 mm
Bolt length	96 mm
Dome-Ø	62 mm
Offset	40 mm
Swivel Interference	230 mm
Overall height	183 mm
Temperature	- 25 / - 25 °C
Standard	EN_12531
Weight	1.106 kg
Swivel Radius	115 mm
Hardness of tread	Shore D 40
Load capacity	150 kg
Load capacity (static)	450 kg

Dimensions

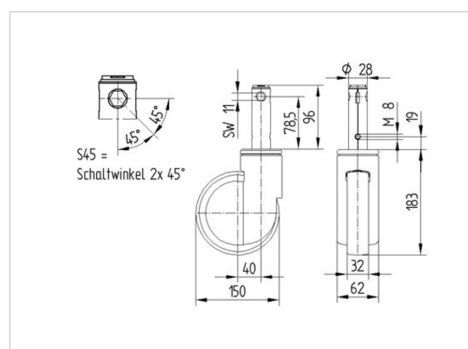

Advantages at a glance

Roll performance	● ● ● ○ ○
Movement noise	● ● ● ○ ○
Attrition	● ● ● ● ○
Corrosion resistance	● ● ● ● ●

INTEGRAL

7046UAX150R26-28S45 4xM8

EAN 4031582311396



BETTER MOBILITY. BETTER LIFE.

Structure & Mounting

