

GALEA

5081PJM125P60-90x70

EAN 4031582368024

Swivel castor with directional lock, housing made of Polyamide, double ball bearing swivel head, plate fitting. Wheel centre made of Polypropylene, Tread: TENTEprene (thermoplastic rubber), rubber non-marking, with threadguards, plain bearing, stainless Stainless Steel version. All Metal parts made of Stainless Steel.



BETTER MOBILITY. BETTER LIFE.



Picture may differ from original product

Technical Data

Wheel diameter	125 mm
Wheel width	30 mm
Size of Plate	90 x 70 mm
Plate hole centres	70/60 x 55/50 mm
Plate hole	8 mm
Offset	40 mm
Swivel Interference	205 mm
Overall height	163 mm
Temperature	-20 / +60 °C
Standard	EN_12530
Weight	0.561 kg
Hardness of tread	Shore A 87
Load capacity	100 kg
Load capacity (static)	200 kg

Structure & Mounting

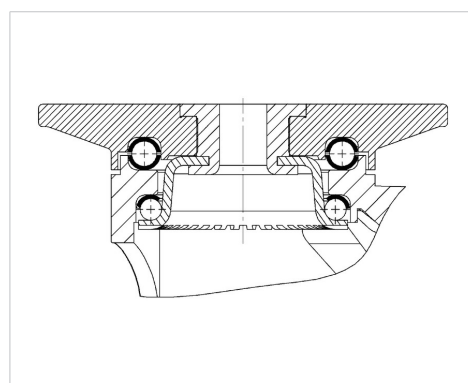

Advantages at a glance

Roll performance	● ● ● ○ ○
Movement noise	● ● ● ○ ○
Attrition	● ● ● ○ ○
Corrosion resistance	● ● ● ● ●