

2471DIK100P50

EAN 4031582301298

Swivel castor with directional lock, housing made of pressed steel, bright zinc plated, blue passivated, double ball bearing swivel head, wheel axle with nut, plate fitting. Wheel centre made of pressed steel, Tread: solid rubber, grey non-marking, with threadguards, cone ball bearing



BETTER MOBILITY. BETTER LIFE.



Picture may differ from original product

Technical Data

Wheel diameter	100 mm
Wheel width	32 mm
Size of Plate	77 x 67 mm
Plate hole centres	61,5/56 x 51,5/46,5 mm
Plate hole	8,5 mm
Offset	43.5 mm
Swivel Interference	262 mm
Overall height	135 mm
Temperature	- 20 / + 85 °C
Standard	EN_12530
Weight	1.06 kg
Swivel Radius	131 mm
Hardness of tread	Shore A 80
Load capacity	80 kg
Load capacity (static)	160 kg

Advantages at a glance

Roll performance	● ● ● ○ ○
Movement noise	● ● ● ○ ○
Attrition	● ● ● ○ ○
Corrosion resistance	● ● ● ○ ○

Dimensions

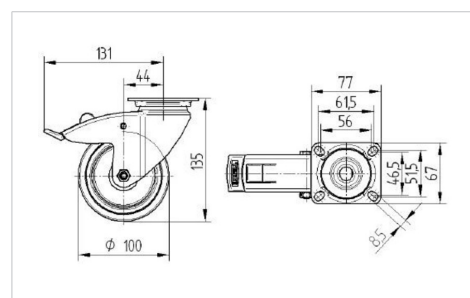

Structure & Mounting

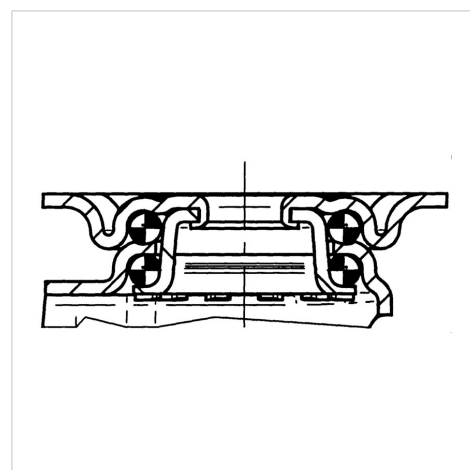



BETTER MOBILITY. BETTER LIFE.

2471DIK100P50

EAN 4031582301298

Structure & Mounting

