

AGILA

2477DYK125P50

EAN 4031582342857

Swivel castor with total lock, tail end of castor, housing made of pressed steel, bright zinc plated, blue passivated, double ball bearing swivel head, wheel axle with nut, plate fitting. Wheel centre made of pressed steel, Tread: solid rubber black, non-staining, electric conductive, with threadguards, cone ball bearing



BETTER MOBILITY. BETTER LIFE.



Picture may differ from original product

Technical Data

Wheel diameter	125 mm
Wheel width	32 mm
Castor width	60 mm
Size of Plate	77 x 67 mm
Plate hole centres	61,5/56 x 51,5/46,5 mm
Plate hole	8,5 mm
Dome-Ø	60 mm
Offset	41 mm
Swivel Interference	262 mm
Overall height	160 mm
Temperature	- 20 / + 85 °C
Standard	EN_12530
Weight	1.277 kg
Swivel Radius	131 mm
Hardness of tread	Shore A 80
Load capacity	100 kg
Load capacity (static)	200 kg

Dimensions

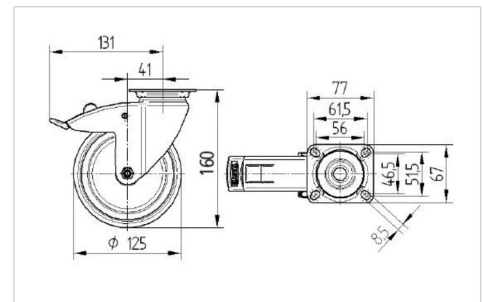

Structure & Mounting

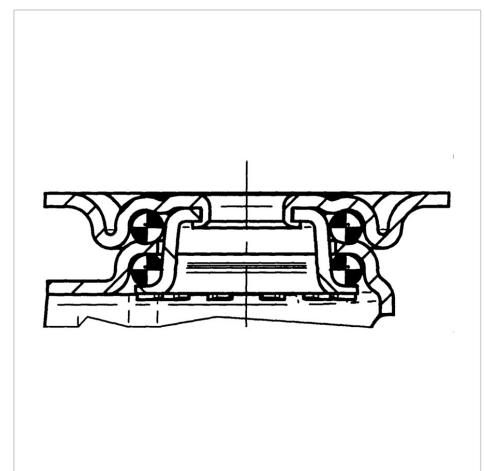

Advantages at a glance

Roll performance	● ● ● ○ ○
Movement noise	● ● ● ○ ○
Attrition	● ● ● ○ ○
Corrosion resistance	● ● ● ○ ○

AGILA

2477DYK125P50

EAN 4031582342857



BETTER MOBILITY. BETTER LIFE.

Structure & Mounting

