

AGILA

2478DYK125P50

EAN 4031582340549

Fixed castor, Fork made of pressed steel, bright zinc plated, blue passivated, wheel axle with nut, plate fitting.

Longside of plate 90° off track.

Wheel centre made of pressed steel, Tread: solid rubber black, non-staining, electric conductive, with threadguards, cone ball bearing



BETTER MOBILITY. BETTER LIFE.



Picture may differ from original product

Technical Data

Wheel diameter	125 mm
Wheel width	32 mm
Castor width	60 mm
Size of Plate	77 x 67 mm
Plate hole centres	61,5/56 x 51,5/46,5 mm
Plate hole	8,5 mm
Dome-Ø	60 mm
Overall height	160 mm
Temperature	- 20 / + 85 °C
Standard	EN_12530
Weight	1.002 kg
Hardness of tread	Shore A 80
Load capacity	100 kg
Load capacity (static)	200 kg

Dimensions

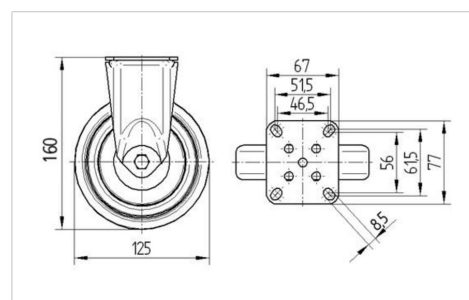

Advantages at a glance

Roll performance	● ● ● ○ ○
Movement noise	● ● ● ○ ○
Attrition	● ● ● ○ ○
Corrosion resistance	● ● ● ○ ○

AGILA

2478DYK125P50

EAN 4031582340549



BETTER MOBILITY. BETTER LIFE.

Structure & Mounting

