

# ZETA

## 4680ITP125P63 Flat

EAN 4031582010626

Swivel castor, housing made of very heavy pressed steel, reinforced, bright zinc plated, blue passivated, sealed swivel double ball bearing, reinforced and heat-treated ball covers, riveted king pin, dust ring with integrated grease nipple, wheel axle with nut, plate fitting. Wheel centre made of Aluminium, Tread: Polyurethane, casted, precision ball bearing



BETTER MOBILITY. BETTER LIFE.



Picture may differ from original product

### Technical Data

|                        |                |
|------------------------|----------------|
| Wheel diameter         | 125 mm         |
| Wheel width            | 50 mm          |
| Castor width           | 96 mm          |
| Size of Plate          | 137 x 105 mm   |
| Plate hole centres     | 105 x 80/75 mm |
| Plate hole             | 11 mm          |
| Dome-Ø                 | 96 mm          |
| Offset                 | 55 mm          |
| Swivel Interference    | 235 mm         |
| Overall height         | 164 mm         |
| Temperature            | - 10 / + 60 °C |
| Standard               | EN_12532       |
| Weight                 | 2.833 kg       |
| Swivel Radius          | 117.5 mm       |
| Hardness of tread      | Shore A 92     |
| Load capacity          | 500 kg         |
| Load capacity (static) | 1000 kg        |

### Dimensions

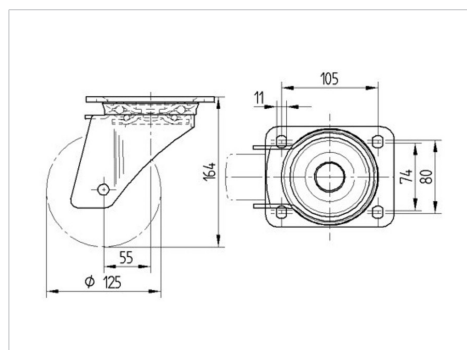

### Structure & Mounting

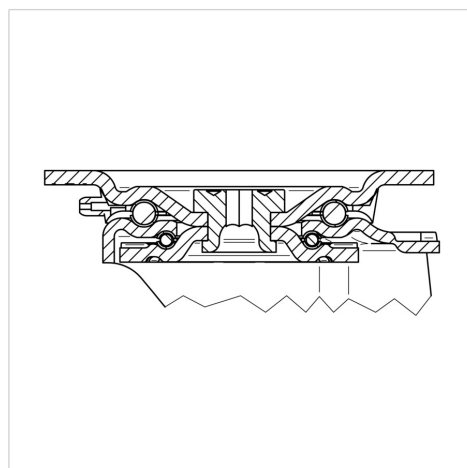

### Advantages at a glance

|                      |           |
|----------------------|-----------|
| Roll performance     | ● ● ● ○ ○ |
| Movement noise       | ● ● ● ○ ○ |
| Attrition            | ● ● ● ● ○ |
| Corrosion resistance | ● ● ● ○ ○ |

# ZETA

## 4680ITP125P63 Flat

EAN 4031582010626



BETTER MOBILITY. BETTER LIFE.

### Structure & Mounting

---

