

INTEGRAL

2044XSX125R26-28S45 4xM8

EAN 4031582340693

Swivel castor with central, total lock and central directional lock, frame made of pressed steel, precision ball bearing in swivel head and wheel, housing cover made of synthetic plastics, stem with cam hole for profile bars. Wheel centre made of Polyamide, electric conductive, Tread made of injected Polyurethane, with threadguards, precision ball bearing, sealed

Hint: TÜV Süd certified product. Washable beds must be sealed in the fitting area by the hospital bed manufacturer.



BETTER MOBILITY. BETTER LIFE.



Picture may differ from original product

Technical Data

Wheel diameter	125 mm
Wheel width	32 mm
Castor width	62 mm
Bolt-Ø	28 mm
Bolt length	96 mm
Dome-Ø	62 mm
Offset	35 mm
Swivel Interference	195 mm
Overall height	158 mm
Temperature	- 25 / - 25 °C
Standard	EN_12531
Weight	0.946 kg
Swivel Radius	97.5 mm
Hardness of tread	Shore D 40
Load capacity	150 kg
Load capacity (static)	450 kg

Dimensions

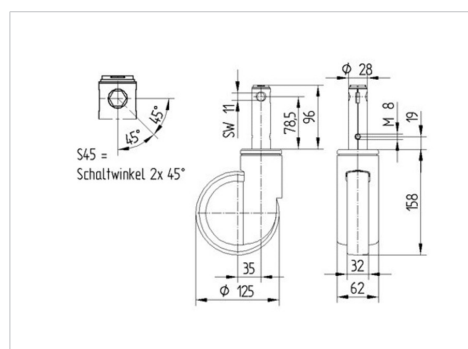

Advantages at a glance

Roll performance	● ● ● ○ ○
Movement noise	● ● ● ○ ○
Attrition	● ● ● ○ ○
Corrosion resistance	● ● ● ○ ○

INTEGRAL

2044XSX125R26-28S45 4xM8

EAN 4031582340693



BETTER MOBILITY. BETTER LIFE.

Structure & Mounting

