

STORA

2875ZAP125P30-11 LEFT

EAN 4031582365320

Walkway Castor with automatic side brake for moving walkways, flanged wheel with one ball race, left and right hand design, housing made of pressed steel, bright zinc plated, blue passivated, double ball bearing swivel head, wheel axle with nut, Wheel centre made of plastic, Tread: Polyurethane, with threadguards, precision ball bearing.

Designed for the following palletsize: track width: approx: 2,75 mm, groove width: approx. 5,7 mm, groove depth: > 10 mm.

Hint:

Load capacity 100 kg per castor on level and securely attached floors, 40 kg per castor on walkways. Use on uneven floors, outdoors (ground beams, gaps, joints, manhole covers, etc.) can affect the life expectancy of castors. Load capacity 80 kg per castor on level and securely attached floors, 40 kg per castor on walkways. Please note that according to EN1929 only castors with a minimum wheel diameter of 120 mm can be used on walkways.



BETTER MOBILITY. BETTER LIFE.



Picture may differ from original product

Technical Data

Wheel diameter	125 mm
Wheel width	32 mm
Centre hole	11 mm
Offset	40 mm
Swivel Interference	205 mm
Overall height	153 mm
Temperature	- 20 / + 60 °C
Standard	EN_12530
Weight	0.886 kg
Swivel Radius	102.5 mm
Load capacity	100 kg
Load capacity (static)	200 kg

Structure & Mounting

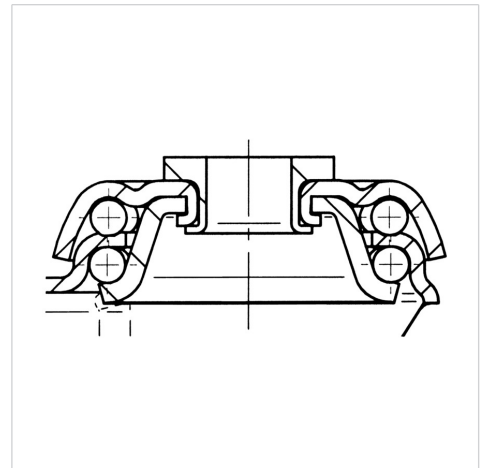

Advantages at a glance

Roll performance	● ● ● ○ ○
Movement noise	● ● ● ○ ○
Attrition	● ● ● ● ○
Corrosion resistance	● ● ● ○ ○

STORA

2875ZAP125P30-11 LEFT

EAN 4031582365320



BETTER MOBILITY. BETTER LIFE.

Structure & Mounting

