

LINEA

5941UAP125P30-11 RAL9002

EAN 4031582369229

Swivel castor with directional lock, housing made of Polyamide, precision ball bearing in swivel head, bolt hole. Wheel centre made of Polyamide, Tread: Polyurethane, precision ball bearing



BETTER MOBILITY. BETTER LIFE.



Picture may differ from original product

Technical Data

Wheel diameter	125 mm
Wheel width	20 mm
Castor width	82 mm
Centre hole	11 mm
Dome-Ø	52 mm
Offset	40 mm
Swivel Interference	258 mm
Overall height	143 mm
Temperature	- 10 / + 40 °C
Standard	EN_12530
Weight	0.955 kg
Swivel Radius	129 mm
Hardness of tread	Shore A 92
Load capacity	130 kg
Load capacity (static)	260 kg

Advantages at a glance

Roll performance	● ● ● ● ●
Movement noise	● ● ● ○ ○
Attrition	● ● ● ● ○
Corrosion resistance	● ● ● ● ○

Dimensions

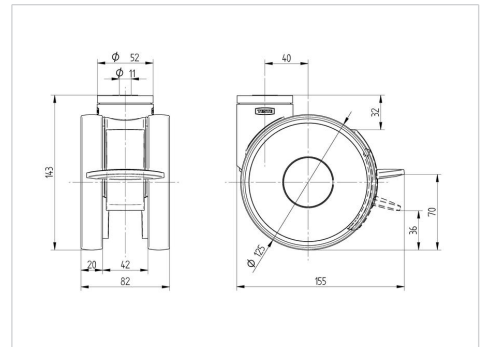

Structure & Mounting

