

# DELTA

3642IEP125P63

EAN 4031582337204

Swivel castor with total lock, head end of castor, housing made of heavy pressed steel, bright zinc plated, blue passivated, precision ball bearing swivel head, sealed, wheel axle with nut, plate fitting. Wheel centre made of Aluminium, Tread: black elastic-tyre, vulcanized, precision ball bearing



BETTER MOBILITY. BETTER LIFE.



Picture may differ from original product

## Technical Data

Wheel diameter	125 mm
Wheel width	50 mm
Castor width	94 mm
Size of Plate	137 x 105 mm
Plate hole centres	105 x 80/75 mm
Plate hole	11 mm
Dome-Ø	94 mm
Offset	55 mm
Swivel Interference	235 mm
Overall height	178 mm
Temperature	- 20 / + 85 °C
Standard	EN_12532
Weight	3.155 kg
Swivel Radius	117.5 mm
Hardness of tread	Shore A 68
Load capacity	300 kg
Load capacity (static)	600 kg

## Advantages at a glance

Roll performance	● ● ● ○ ○
Movement noise	● ● ● ○ ○
Attrition	● ● ● ○ ○
Corrosion resistance	● ● ● ○ ○

## Dimensions

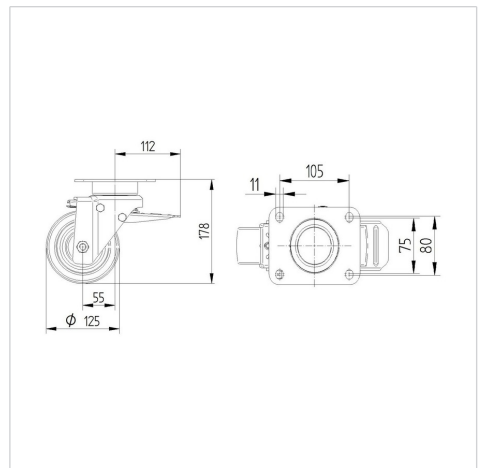

## Structure & Mounting

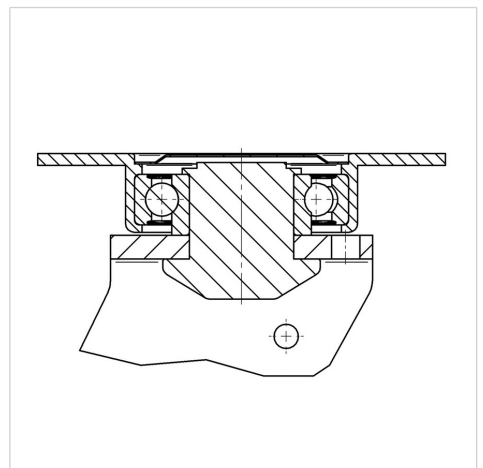

# DELTA

3642IEP125P63

EAN 4031582337204



BETTER MOBILITY. BETTER LIFE.

## Structure & Mounting

