

DELTA

3642ITP125P63 Flat

EAN 4031582337419

Swivel castor with total lock, head end of castor, housing made of heavy pressed steel, bright zinc plated, blue passivated, precision ball bearing swivel head, sealed, wheel axle with nut, plate fitting. Wheel centre made of Aluminium, Tread: Polyurethane, casted, precision ball bearing



BETTER MOBILITY. BETTER LIFE.



Picture may differ from original product

Technical Data

Wheel diameter	125 mm
Wheel width	50 mm
Castor width	94 mm
Size of Plate	137 x 105 mm
Plate hole centres	105 x 80/75 mm
Plate hole	11 mm
Dome-Ø	94 mm
Offset	55 mm
Swivel Interference	235 mm
Overall height	178 mm
Temperature	- 10 / + 60 °C
Standard	EN_12532
Weight	2.958 kg
Swivel Radius	117.5 mm
Hardness of tread	Shore A 92
Load capacity	500 kg
Load capacity (static)	1000 kg

Dimensions

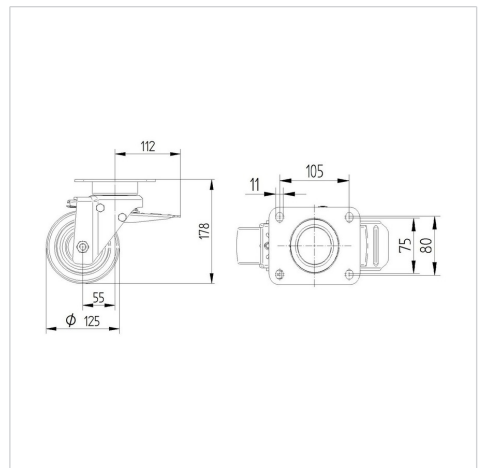

Structure & Mounting

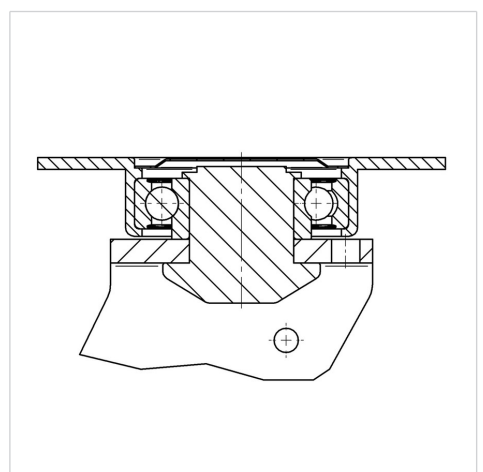

Advantages at a glance

Roll performance	● ● ● ○ ○
Movement noise	● ● ● ○ ○
Attrition	● ● ● ● ○
Corrosion resistance	● ● ● ○ ○

DELTA

3642ITP125P63 Flat

EAN 4031582337419



BETTER MOBILITY. BETTER LIFE.

Structure & Mounting

