



BETTER MOBILITY. BETTER LIFE.

## 5327PJP100S70

EAN 4031582367485

Swivel castor with total lock, tail end of castor, housing and wheels made from high grade synthetic materials, with integrated threadguards, all metal parts are bright zinc plated, yellow thick layer passivated, threaded stem with hexagon neck. Wheel centre made of Polypropylene, Tread: TENTEprene (thermoplastic rubber), grey non-marking, precision ball bearing, with threadguards Please read the assembly instructions in the service area of the TENTE website.

Hint: These castors are also with grey locking lever available.



Picture may differ from original product

### Technical Data

Wheel diameter	100 mm
Wheel width	32 mm
Threaded stem	M 10 x 17 mm
Offset	37 mm
Swivel Interference	240 mm
Overall height	137 mm
Temperature	- 10 / + 40 °C
Standard	EN_12530
Weight	0.463 kg
Hardness of tread	Shore A 87
Load capacity	100 kg
Load capacity (static)	200 kg

### Advantages at a glance

Roll performance	● ● ● ○ ○
Movement noise	● ● ● ● ○
Attrition	● ● ● ○ ○
Corrosion resistance	● ● ● ● ○

### Dimensions

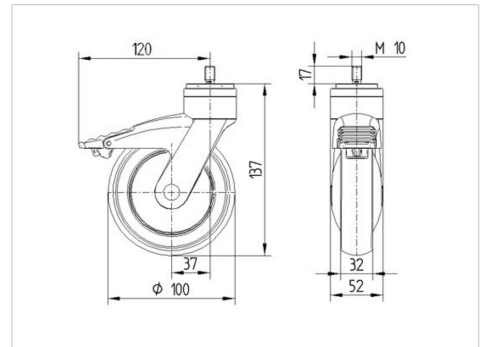

### Structure & Mounting

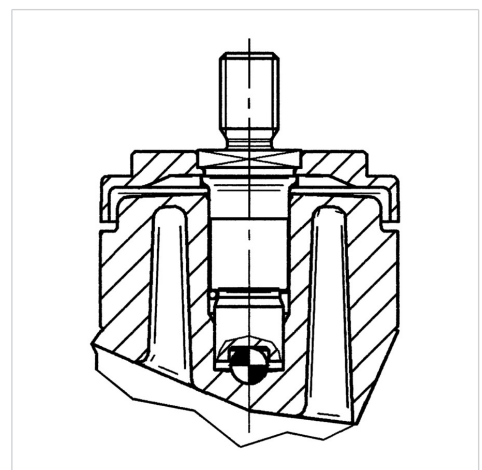



BETTER MOBILITY. BETTER LIFE.

5327PJP100S70

EAN 4031582367485

**Structure & Mounting**

---

