

# DELTA TWIN

9940U00125P63

EAN 4031582366792

Swivel castor, housing made of heavy pressed steel, bright zinc plated, blue passivated, precision ball bearing swivel head, sealed, wheel axle with nut, plate fitting. Wheel centre made of Polyamide, plain bearing



BETTER MOBILITY. BETTER LIFE.



Picture may differ from original product

## Technical Data

Wheel diameter	125 mm
Wheel width	43 mm
Castor width	157 mm
Size of Plate	137 x 105 mm
Plate hole centres	105 x 80/75 mm
Plate hole	11 mm
Dome-Ø	136 mm
Offset	55 mm
Swivel Interference	253 mm
Overall height	178 mm
Temperature	- 40 / + 85 °C
Standard	EN_12532
Weight	3.652 kg
Swivel Radius	126.5 mm
Hardness of tread	Shore D 75
Load capacity	750 kg
Load capacity (static)	1500 kg

## Advantages at a glance

Roll performance	● ● ● ○ ○
Movement noise	● ● ● ○ ○
Attrition	● ● ● ● ○
Corrosion resistance	● ● ● ○ ○

## Dimensions

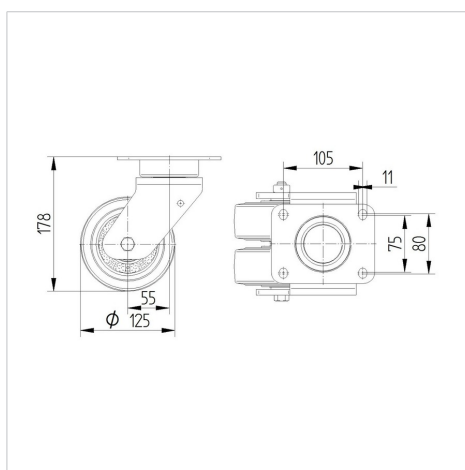

## Structure & Mounting

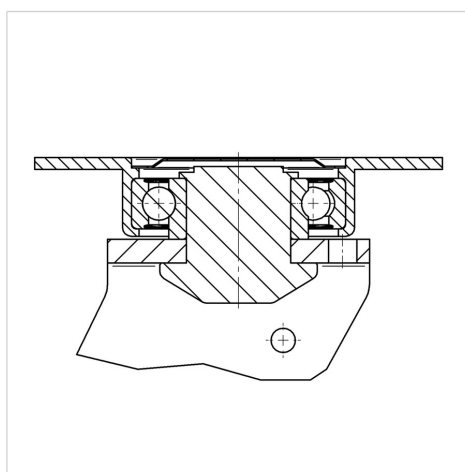

# DELTA TWIN

9940U00125P63

EAN 4031582366792



BETTER MOBILITY. BETTER LIFE.

## Structure & Mounting

