

# LEVINA

5387UAC125P30-11

EAN 4031582368901

Swivel castor with total lock, tail end of castor, housing made from high grade synthetic materials with metal parts made of Stainless Steel, double ball bearing swivel head, bolt hole. Wheel centre made of polyamide, tread made of polyurethane, two INOX precision ball bearings, sealed, washable

Hint: These castors are also with grey locking lever available.



BETTER MOBILITY. BETTER LIFE.



Picture may differ from original product

## Technical Data

Wheel diameter	125 mm
Wheel width	32 mm
Centre hole	11 mm
Offset	38 mm
Swivel Interference	201 mm
Overall height	161 mm
Temperature	- 10 / + 40 °C
Standard	EN_12530
Weight	0.649 kg
Swivel Radius	100.5 mm
Hardness of tread	Shore D 40
Load capacity	100 kg
Load capacity (static)	200 kg

## Advantages at a glance

Roll performance	● ● ● ○ ○
Movement noise	● ● ● ● ○
Attrition	● ● ● ● ○
Corrosion resistance	● ● ● ● ●

## Dimensions

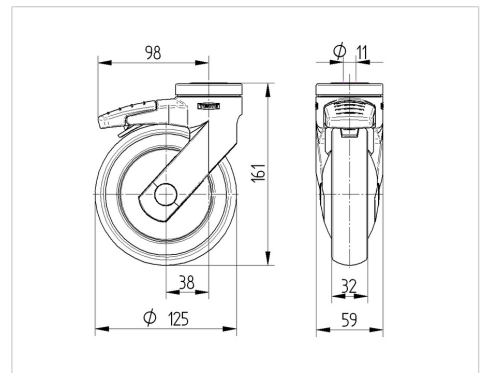

## Structure & Mounting

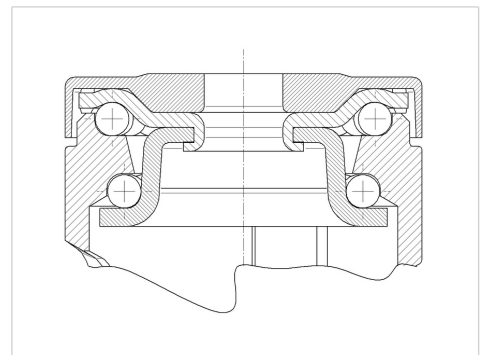

PRODUCT INFORMATION

# LEVINA

5387UAC125P30-11

EAN 4031582368901



BETTER MOBILITY. BETTER LIFE.

## Structure & Mounting

---

