

5075PJH125P30-12

EAN 4031582379341

Swivel castor with wheel brake, housing made of Polyamide, double ball bearing swivel head, bolt hole. Wheel centre made of Polypropylene, Tread: TENTEprene (thermoplastic rubber), grey non-marking, with threadguards, plain bearing



BETTER MOBILITY. BETTER LIFE.



Picture may differ from original product

Technical Data

Wheel diameter	125 mm
Wheel width	30 mm
Castor width	66 mm
Centre hole	12 mm
Dome-Ø	59 mm
Offset	40 mm
Swivel Interference	258 mm
Overall height	162 mm
Temperature	-20 / +60 °C
Standard	EN_12530
Weight	0.541 kg
Swivel Radius	129 mm
Hardness of tread	Shore A 87
Load capacity	100 kg
Load capacity (static)	200 kg

Advantages at a glance

Roll performance	● ● ● ○ ○
Movement noise	● ● ● ○ ○
Attrition	● ● ● ● ○
Corrosion resistance	● ● ● ○ ○

Dimensions

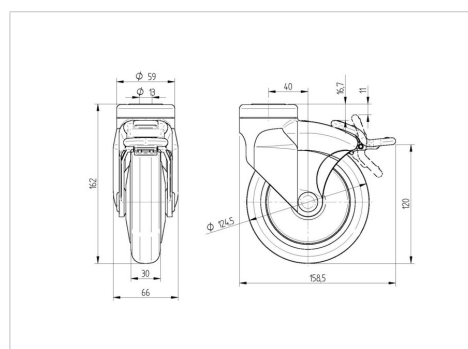

Structure & Mounting

