

AGILA

2470DIK075P40

EAN 4031582010343

Swivel castor, housing made of pressed steel, bright zinc plated, blue passivated, double ball bearing swivel head, plate fitting. Wheel centre made of pressed steel, Tread: solid rubber, grey non-marking, with threadguards, cone ball bearing



BETTER MOBILITY. BETTER LIFE.



Picture may differ from original product

Technical Data

Wheel diameter	75 mm
Wheel width	25 mm
Castor width	43 mm
Size of Plate	60 x 60 mm
Plate hole centres	48/38 x 48/38 mm
Plate hole	6,3 mm
Dome-Ø	43 mm
Offset	24 mm
Swivel Interference	123 mm
Overall height	100 mm
Temperature	- 20 / + 85 °C
Standard	EN_12530
Weight	0.397 kg
Swivel Radius	61.5 mm
Hardness of tread	Shore A 80
Load capacity	55 kg
Load capacity (static)	110 kg

Dimensions

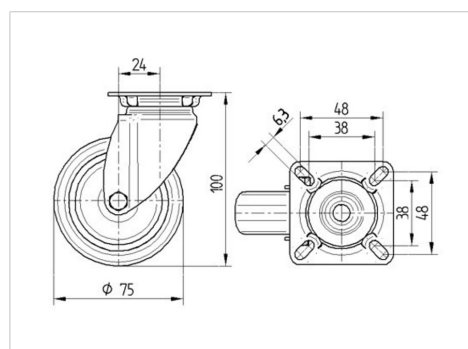

Structure & Mounting

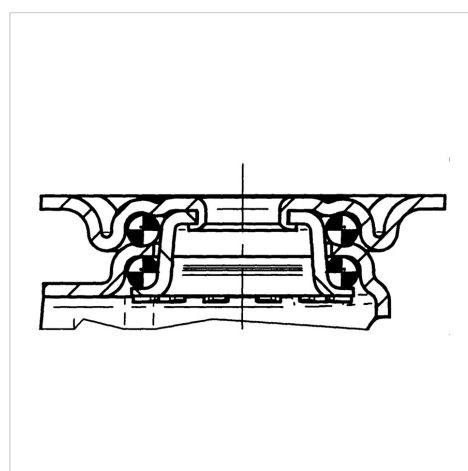

Advantages at a glance

Roll performance	● ● ● ○ ○
Movement noise	● ● ● ○ ○
Attrition	● ● ● ○ ○
Corrosion resistance	● ● ● ○ ○

AGILA

2470DIK075P40

EAN 4031582010343



BETTER MOBILITY. BETTER LIFE.

Structure & Mounting

