

GALEA

5070PJH125R05-22x40

EAN 4031582308655

Swivel castor, housing made of Polyamide, double ball bearing swivel head, solid plug fitting. Wheel centre made of Polypropylene, Tread: TENTEprene (thermoplastic rubber), grey non-marking, with threadguards, plain bearing



BETTER MOBILITY. BETTER LIFE.



Picture may differ from original product

Technical Data

Wheel diameter	125 mm
Wheel width	30 mm
Bolt-Ø	22 mm
Bolt length	40 mm
Offset	40 mm
Swivel Interference	205 mm
Overall height	162 mm
Temperature	-20 / +60 °C
Standard	EN_12530
Weight	0.093 kg
Swivel Radius	102.5 mm
Hardness of tread	Shore A 87
Load capacity	100 kg
Load capacity (static)	200 kg

Advantages at a glance

Roll performance	● ● ● ○ ○
Movement noise	● ● ● ○ ○
Attrition	● ● ● ○ ○
Corrosion resistance	● ● ● ● ○

Dimensions

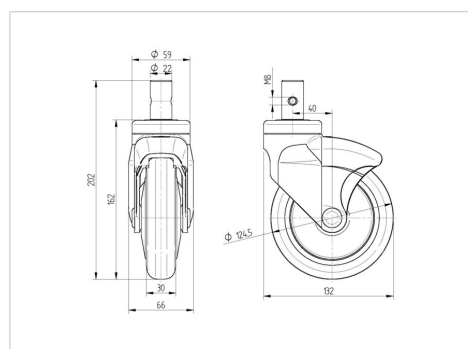

Structure & Mounting

