

INTEGRAL

2070PIP150R05-32

EAN 4031582360851

Swivel castor, housing made of pressed steel, bright zinc plated, blue passivated, double ball bearing swivel head, wheel axle riveted for attaching the cover, covering of the housing made of Polypropylene, RAL 9002 grey-white, solid plug fitting. Wheel centre made of Polypropylene, Tread: solid rubber, grey non-marking, precision ball bearing



BETTER MOBILITY. BETTER LIFE.



Picture may differ from original product

Technical Data

Wheel diameter	150 mm
Wheel width	32 mm
Bolt-Ø	32 mm
Bolt length	45 mm
Offset	45 mm
Swivel Interference	240 mm
Overall height	188 mm
Temperature	- 20 / + 60 °C
Standard	EN_12530
Swivel Radius	120 mm
Hardness of tread	Shore A 75
Load capacity	80 kg
Load capacity (static)	160 kg

Structure & Mounting

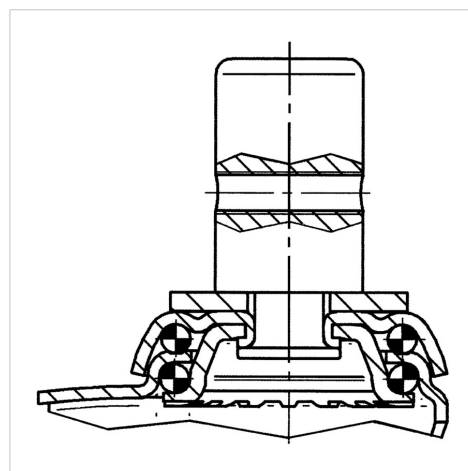

Advantages at a glance

Roll performance	● ● ● ○ ○
Movement noise	● ● ● ○ ○
Attrition	● ● ● ○ ○
Corrosion resistance	● ● ● ○ ○