

AGILA

2477PJP100R05-28

EAN 4031582302127

Swivel castor with total lock, tail end of castor, housing made of pressed steel, bright zinc plated, blue passivated, double ball bearing swivel head, wheel axle with nut, solid plug fitting. Wheel centre made of Polypropylene, Tread: TENTEprene (thermoplastic rubber), grey non-marking, precision ball bearing, with threadguards



BETTER MOBILITY. BETTER LIFE.



Picture may differ from original product

Technical Data

Wheel diameter	100 mm
Wheel width	32 mm
Castor width	60 mm
Bolt-Ø	28 mm
Bolt length	45 mm
Dome-Ø	60 mm
Offset	43.5 mm
Swivel Interference	262 mm
Overall height	138 mm
Temperature	- 20 / + 60 °C
Standard	EN_12530
Weight	1.03 kg
Swivel Radius	131 mm
Hardness of tread	Shore A 87
Load capacity	100 kg
Load capacity (static)	200 kg

Advantages at a glance

Roll performance	● ● ● ○ ○
Movement noise	● ● ● ○ ○
Attrition	● ● ● ○ ○
Corrosion resistance	● ● ● ○ ○

Dimensions

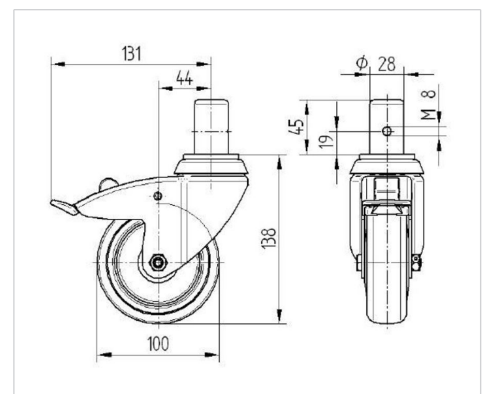

Structure & Mounting

