

# LUMINA

5520UAI075L51-11 RAL9006

EAN 4031582310634

Swivel castor, housing made of Polyamide, with blind hole fitting. Wheel centre made of Polyamide, Tread: Polyurethane, plain bearing



BETTER MOBILITY. BETTER LIFE.



Picture may differ from original product

## Technical Data

Wheel diameter	75 mm
Wheel width	10 mm
Castor width	65 mm
Centre hole	11 mm
Dome-Ø	45 mm
Offset	30 mm
Swivel Interference	146 mm
Overall height	88 mm
Temperature	- 20 / + 60 °C
Standard	EN_12528
Weight	0.28 kg
Swivel Radius	73 mm
Hardness of tread	Shore A 92
Load capacity	100 kg
Load capacity (static)	200 kg

## Structure & Mounting

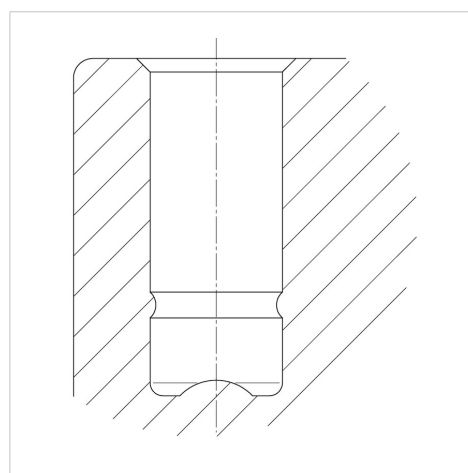

## Advantages at a glance

Roll performance	● ● ● ○ ○
Movement noise	● ● ● ○ ○
Attrition	● ● ● ○ ○
Corrosion resistance	● ● ● ● ○