

AGILA

2470UAP150R47-32-35

EAN 4031582325836

Swivel castor, housing made of pressed steel, bright zinc plated, blue passivated, double ball bearing swivel head, wheel axle with nut, expanding fitting (square). Wheel centre made of Polyamide, Tread: Polyurethane, precision ball bearing, with threadguards Please indicate required tube innerdiameter when ordering.



BETTER MOBILITY. BETTER LIFE.



Picture may differ from original product

Technical Data

Wheel diameter	150 mm
Wheel width	32 mm
Expanding fitting-Ø	32 - 35 mm
Offset	45 mm
Swivel Interference	240 mm
Overall height	188 mm
Temperature	- 10 / + 40 °C
Standard	EN_12530
Swivel Radius	120 mm
Hardness of tread	Shore D 40
Load capacity	100 kg
Load capacity (static)	200 kg

Advantages at a glance

Roll performance	● ● ● ○ ○
Movement noise	● ● ● ○ ○
Attrition	● ● ● ● ○
Corrosion resistance	● ● ● ○ ○

Dimensions

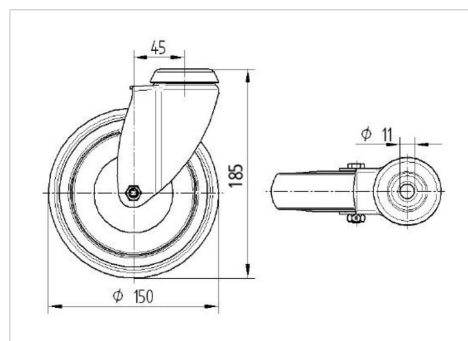

Structure & Mounting

