

AGILA

2470UAP050P30-11

EAN 4031582324631

Swivel castor, housing made of pressed steel, bright zinc plated, blue passivated, double ball bearing swivel head, bolt hole. Wheel centre made of Polyamide, Tread: Polyurethane, precision ball bearing, with threadguards Castors can be mounted with standard screws of any length.



BETTER MOBILITY. BETTER LIFE.



Picture may differ from original product

Technical Data

Wheel diameter	50 mm
Wheel width	20 mm
Castor width	43 mm
Centre hole	11 mm
Dome-Ø	41 mm
Offset	24 mm
Swivel Interference	98 mm
Overall height	69 mm
Temperature	- 25 / - 25 °C
Standard	EN_12530
Weight	0.165 kg
Swivel Radius	49 mm
Hardness of tread	Shore D 42
Load capacity	40 kg
Load capacity (static)	80 kg

Advantages at a glance

Roll performance	● ● ● ○ ○
Movement noise	● ● ● ○ ○
Attrition	● ● ● ● ○
Corrosion resistance	● ● ● ○ ○

Dimensions

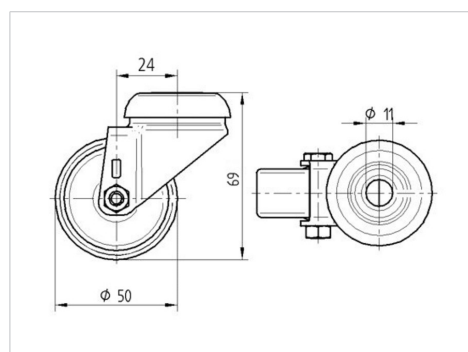

Structure & Mounting

