



BETTER MOBILITY. BETTER LIFE.

## FOOT MASTER GAAD-125-ASF-HUD

EAN 4031582495171

Swivel twin wheel castor, housing made of steel welded, zinc plated, taper roller bearing with hardened treatment in the swivel head (125/150 series: double thrust bearing), grease nipple, self-aligned function with two swiveling axes with different swiveling radii, wheel axle with nut, plate fitting. Wheel centre made of cast iron, Tread: Polyurethane, casted, precision ball bearing.



Picture may differ from original product

### Technical Data

Wheel diameter	125 mm
Wheel width	35 mm
Castor width	128 mm
Size of Plate	145 x 145,0 mm
Plate hole centres	120 x 120 mm
Plate hole	11 mm
Dome-Ø	128 mm
Offset	33 mm
Swivel Interference	200 mm
Overall height	190 mm
Temperature	-10 / +90 °C
Weight	11.85 kg
Swivel Radius	100 mm
Load capacity	440 kg

### Dimensions

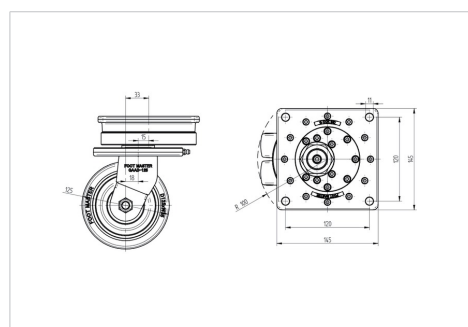

### Advantages at a glance

Roll performance	● ● ● ● ●
Movement noise	● ● ● ● ○
Attrition	● ● ● ● ○
Corrosion resistance	● ● ● ● ○