

LEVINA

5371PJP125P50

EAN 4031582358742

Swivel castor with directional lock, housing and wheels made from high grade synthetic materials, double ball bearing swivel head, plate fitting. Wheel centre made of Polypropylene, Tread: TENTEprene (thermoplastic rubber), grey non-marking, precision ball bearing



BETTER MOBILITY. BETTER LIFE.



Picture may differ from original product

Technical Data

Wheel diameter	125 mm
Wheel width	32 mm
Castor width	59 mm
Size of Plate	77 x 67 mm
Plate hole centres	61,5/56 x 51,5/46,5 mm
Plate hole	8,5 mm
Dome-Ø	59 mm
Offset	38 mm
Swivel Interference	201 mm
Overall height	161 mm
Temperature	- 10 / + 40 °C
Standard	EN_12530
Weight	0.609 kg
Swivel Radius	100.5 mm
Hardness of tread	Shore A 87
Load capacity	100 kg
Load capacity (static)	200 kg

Dimensions

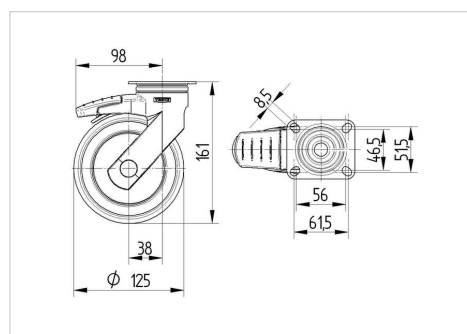

Structure & Mounting

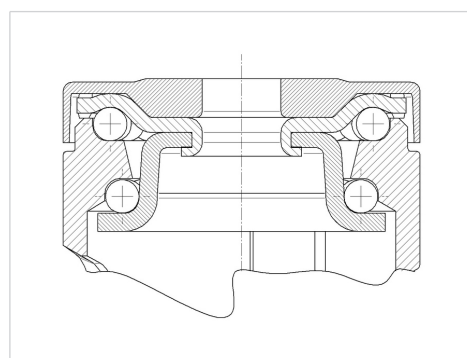

Advantages at a glance

Roll performance	● ● ● ○ ○
Movement noise	● ● ● ● ○
Attrition	● ● ● ○ ○
Corrosion resistance	● ● ● ● ○

LEVINA

5371PJP125P50

EAN 4031582358742



BETTER MOBILITY. BETTER LIFE.

Structure & Mounting

