

DELTA TWIN

9942ITP160P63 SH80

EAN 4031582365795

Swivel castor with total lock, head end of castor, housing made of heavy pressed steel, bright zinc plated, blue passivated, precision ball bearing swivel head, sealed, wheel axle with nut, plate fitting. Wheel centre made of Aluminium, Tread: Polyurethane, casted, precision ball bearing



BETTER MOBILITY. BETTER LIFE.



Picture may differ from original product

Technical Data

Wheel diameter	160 mm
Wheel width	50 mm
Castor width	157 mm
Size of Plate	137 x 105 mm
Plate hole centres	105 x 80/75 mm
Plate hole	11 mm
Dome-Ø	136 mm
Offset	55 mm
Swivel Interference	318 mm
Overall height	210 mm
Temperature	- 10 / + 60 °C
Standard	EN_12532
Weight	6.57 kg
Swivel Radius	159 mm
Hardness of tread	Shore A 80
Load capacity	750 kg
Load capacity (static)	1500 kg

Advantages at a glance

Roll performance	● ● ● ○ ○
Movement noise	● ● ● ○ ○
Attrition	● ● ● ● ○
Corrosion resistance	● ● ● ○ ○

Dimensions

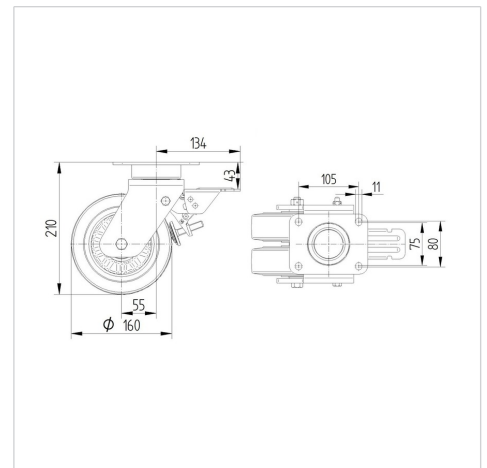

Structure & Mounting

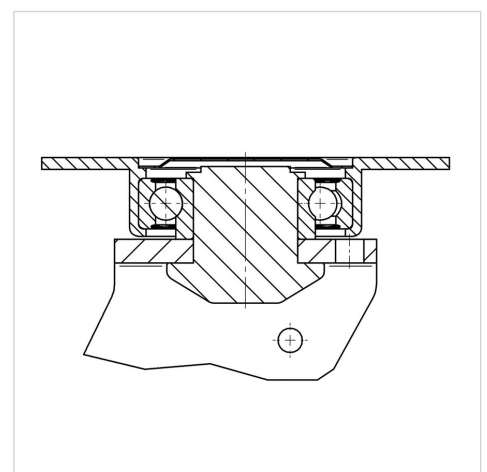

DELTA TWIN

9942ITP160P63 SH80

EAN 4031582365795



BETTER MOBILITY. BETTER LIFE.

Structure & Mounting

