

ANIKA

5925UAI055L51-10 Dom18

EAN 4031582459913

Swivel castor with wheel brake, housing made of Polyamide, with blind hole fitting. Wheel centre made of Polyamide, Tread: Polyurethane, plain bearing



BETTER MOBILITY. BETTER LIFE.



Picture may differ from original product

Technical Data

Wheel diameter	55 mm
Wheel width	11 mm
Castor width	37.5 mm
Centre hole	10 mm
Dome-Ø	18 mm
Offset	17 mm
Swivel Interference	128 mm
Overall height	57 mm
Temperature	- 10 / + 40 °C
Standard	EN_12528
Weight	0.71 kg
Swivel Radius	64 mm
Hardness of tread	Shore A 92
Load capacity	40 kg
Load capacity (static)	80 kg

Structure & Mounting

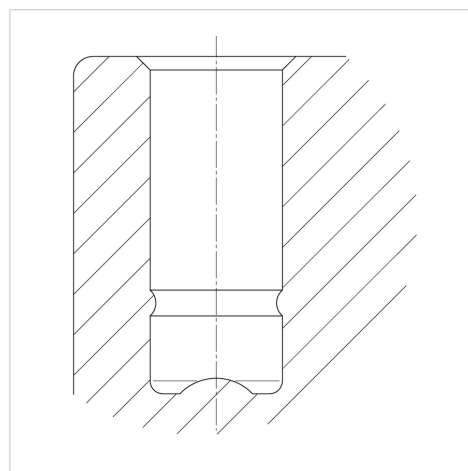

Advantages at a glance

Roll performance	● ● ● ○ ○
Movement noise	● ● ● ○ ○
Attrition	● ● ● ○ ○
Corrosion resistance	● ● ● ● ○