

ZETA

4681IEP250P63

EAN 4031582307962

Swivel castor with directional lock, housing made of very heavy pressed steel, reinforced, bright zinc plated, blue passivated, sealed swivel double ball bearing, reinforced and heat-treated ball covers, riveted king pin, dust ring with integrated grease nipple, wheel axle with nut, plate fitting. Wheel centre made of Aluminium, Tread: black elastic-tyre, vulcanized, precision ball bearing



BETTER MOBILITY. BETTER LIFE.



Picture may differ from original product

Technical Data

Wheel diameter	250 mm
Wheel width	50 mm
Castor width	96 mm
Size of Plate	137 x 105 mm
Plate hole centres	105 x 80/75 mm
Plate hole	11 mm
Dome-Ø	96 mm
Offset	55 mm
Swivel Interference	230 mm
Overall height	290 mm
Temperature	- 20 / + 85 °C
Standard	EN_12532
Weight	4.791 kg
Hardness of tread	Shore A 67
Load capacity	500 kg
Load capacity (static)	1000 kg

Dimensions

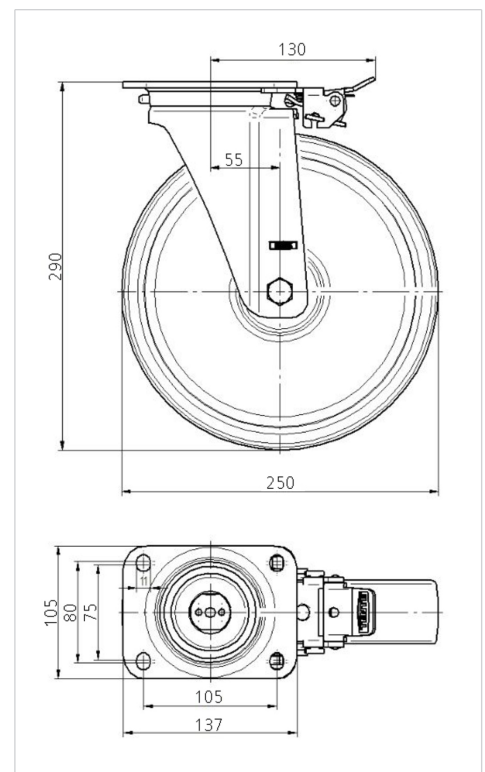

Advantages at a glance

Roll performance	● ● ● ○ ○
Movement noise	● ● ● ○ ○
Attrition	● ● ● ○ ○
Corrosion resistance	● ● ● ○ ○

Structure & Mounting

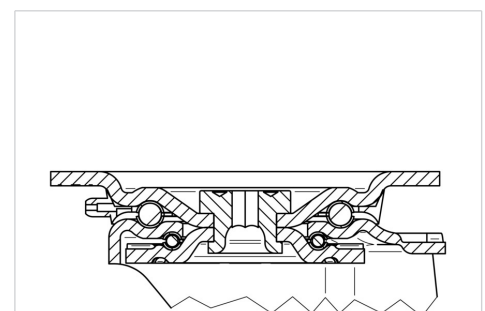

ZETA

4681IEP250P63

EAN 4031582307962



BETTER MOBILITY. BETTER LIFE.

Structure & Mounting

