

AGILA

2470PJO075B10-11x31

EAN 4031582403763

Swivel castor, housing made of pressed steel, bright zinc plated, blue passivated, double ball bearing swivel head, stem with circlip. Wheel centre made of Polypropylene, Tread: TENTEprene (thermoplastic rubber), grey non-marking, plain bearing



BETTER MOBILITY. BETTER LIFE.



Picture may differ from original product

Technical Data

Wheel diameter	75 mm
Wheel width	25 mm
Castor width	43 mm
Metal stem with circlip	11 x 31 mm
Dome-Ø	43 mm
Offset	24 mm
Swivel Interference	123 mm
Overall height	103 mm
Temperature	- 20 / + 60 °C
Standard	EN_12530
Weight	0.241 kg
Swivel Radius	61.5 mm
Hardness of tread	Shore A 87
Load capacity	60 kg
Load capacity (static)	120 kg

Structure & Mounting

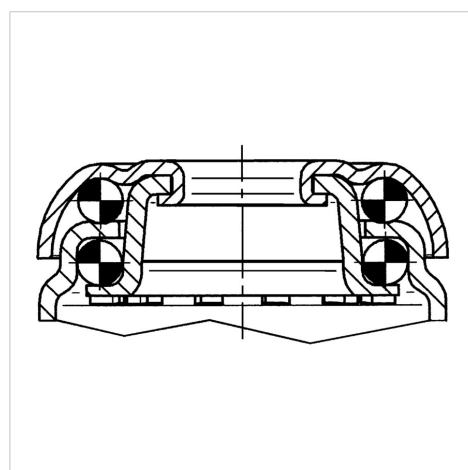

Advantages at a glance

Roll performance	● ● ● ○ ○
Movement noise	● ● ● ○ ○
Attrition	● ● ● ○ ○
Corrosion resistance	● ● ● ○ ○