

AGILA

2477DYK075R47-32-35

EAN 4031582341515

Swivel castor with total lock, tail end of castor, housing made of pressed steel, bright zinc plated, blue passivated, double ball bearing swivel head, expanding fitting (square). Wheel centre made of pressed steel, Tread: solid rubber black, non-staining, electric conductive, with threadguards, cone ball bearing. Please indicate required tube innerdiameter when ordering.



BETTER MOBILITY. BETTER LIFE.



Picture may differ from original product

Technical Data

Wheel diameter	75 mm
Wheel width	25 mm
Expanding fitting-Ø	32 - 35 mm
Offset	24 mm
Swivel Interference	160 mm
Overall height	103 mm
Temperature	- 10 / + 40 °C
Standard	EN_12530
Swivel Radius	80 mm
Hardness of tread	Shore A 80
Load capacity	55 kg
Load capacity (static)	110 kg

Advantages at a glance

Roll performance	● ● ● ○ ○
Movement noise	● ● ● ○ ○
Attrition	● ● ● ○ ○
Corrosion resistance	● ● ● ○ ○

Dimensions

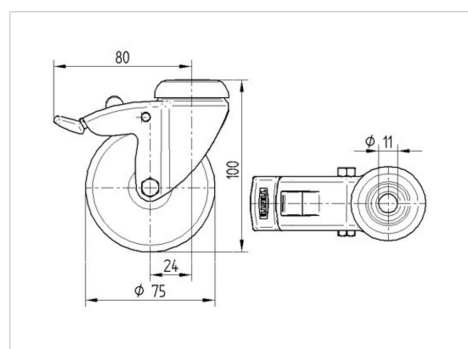

Structure & Mounting

