

AGILA

2477DYK100R07-Ø19-21,5

EAN 4031582342031

Swivel castor with total lock, tail end of castor, housing made of pressed steel, bright zinc plated, blue passivated, double ball bearing swivel head, wheel axle with nut, Expanding fittings, round. Wheel centre made of pressed steel, Tread: solid rubber black, non-staining, electric conductive, with threadguards, cone ball bearing. Please indicate required tube innerdiameter when ordering.



BETTER MOBILITY. BETTER LIFE.



Picture may differ from original product

Technical Data

Wheel diameter	100 mm
Wheel width	32 mm
Expanding fitting-Ø	19 - 21,5 mm
Offset	43.5 mm
Swivel Interference	262 mm
Overall height	138 mm
Temperature	- 10 / + 40 °C
Standard	EN_12530
Weight	1.11 kg
Swivel Radius	131 mm
Hardness of tread	Shore A 80
Load capacity	80 kg
Load capacity (static)	160 kg

Advantages at a glance

Roll performance	● ● ● ○ ○
Movement noise	● ● ● ○ ○
Attrition	● ● ● ○ ○
Corrosion resistance	● ● ● ○ ○

Dimensions

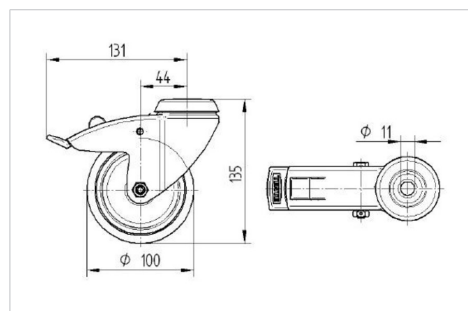

Structure & Mounting

