

INTEGRAL TWIN

2940USX100R05-28

EAN 4031582341195

Swivel castor, frame made of pressed steel, precision ball bearing in swivel head, housing with synthetic cover, solid plug fitting. Wheel centre made of Polyamide, electric conductive, tread made of injected Polyurethane, with threadguards, precision ball bearing, sealed
 Hint: TÜV Süd certified product. Washable beds must be sealed in the fitting area by the hospital bed manufacturer.



BETTER MOBILITY. BETTER LIFE.



Picture may differ from original product

Technical Data

Wheel diameter	100 mm
Wheel width	15 mm
Castor width	63 mm
Bolt-Ø	28 mm
Bolt length	45 mm
Dome-Ø	61.5 mm
Offset	31 mm
Swivel Interference	170 mm
Overall height	129 mm
Temperature	- 25 / - 25 °C
Standard	EN_12531
Weight	1.102 kg
Swivel Radius	85 mm
Hardness of tread	Shore D 40
Load capacity	125 kg
Load capacity (static)	375 kg

Structure & Mounting

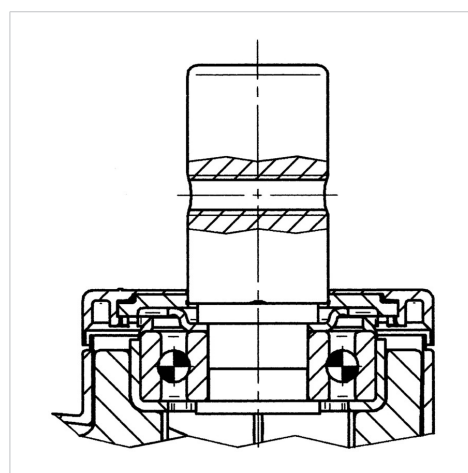

Advantages at a glance

Roll performance	● ● ● ● ●
Movement noise	● ● ● ○ ○
Attrition	● ● ● ● ○
Corrosion resistance	● ● ● ○ ○

INTEGRAL TWIN

2940USX100R05-28

EAN 4031582341195



BETTER MOBILITY. BETTER LIFE.

Structure & Mounting

